

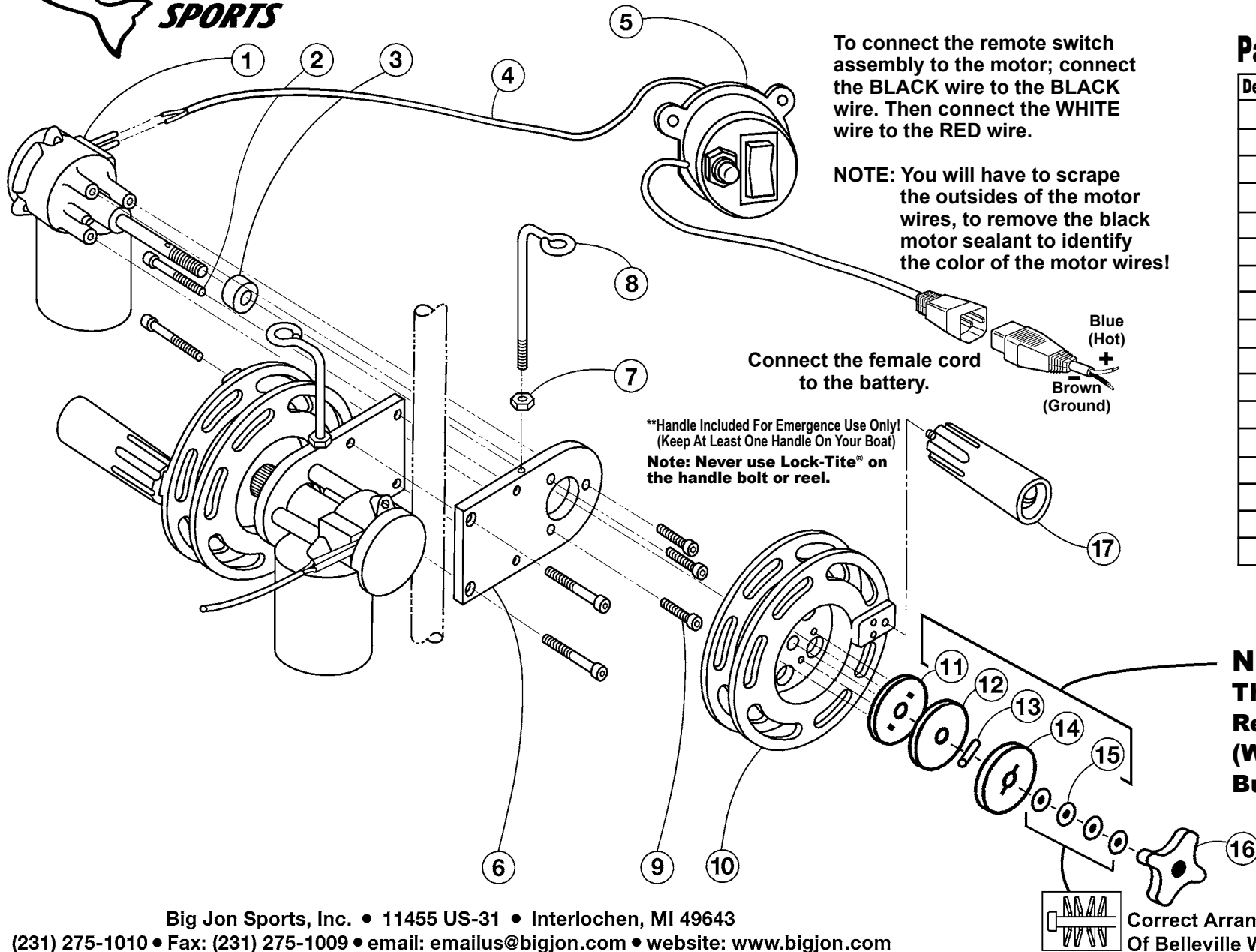

Dual Electric Planer Reel



Parts List PM00002

Detail No.	Description	Qty.	Order By Part No.
1	Motor Assembly	2	KT2205C
2	1/4-20 x 2-1/4 in. SH Cap Screws	4	2145
3	Hardened Spacer	2	51059
4	20 ft. Power Cord	2	2550
5	Remote Switch Assembly	2	KT51145ASM2
6	Reel Clamp Plate	2	53000
7	1/4-20 SS Hex Nuts	2	2133
8	Guide / Eye	2	2500
9	1/4-28 x 1 in. SH Screws	6	2007
10	6 in. Reel	2	KT51174B
11	Inner Clutch Disks	2	KT51098
12	Graphite Pads	2	KT2308
13	Shaft Dowel Pins	2	2163
14	Outer Clutch Disks	2	KT51094
15	Belleville Washers	2	KT2232
16	Jr. Clutch Knob	8	KT51153
17	Handle Assembly	2	KTHA101