



Owner's Manual
A Guide To The Installation
And Use Of Big Jon Sports®
Trolling Equipment

Planning Your Trolling Boat

A well planned boat insures an easier, safer and more enjoyable fishing trip. Before mounting your Big Jon Sports® downriggers, planer riggers and rod holders, it is a good idea to get in the boat with your fishing buddies and locate the best placement of all trolling equipment. Every thing should be easily accessible to all members in your fishing party. On the following pages are some examples of popular layouts for a variety of fishing boats.

Downriggers Mounted On The Transom Of A Tiller Steered Boat...

For the owner of a small or mid-sized boat (with tiller steering) who often fishes by themselves, mounting a pair of downriggers on the transom is a practical choice. This layout keeps all essential equipment within reach and eliminates the need to move around the boat.

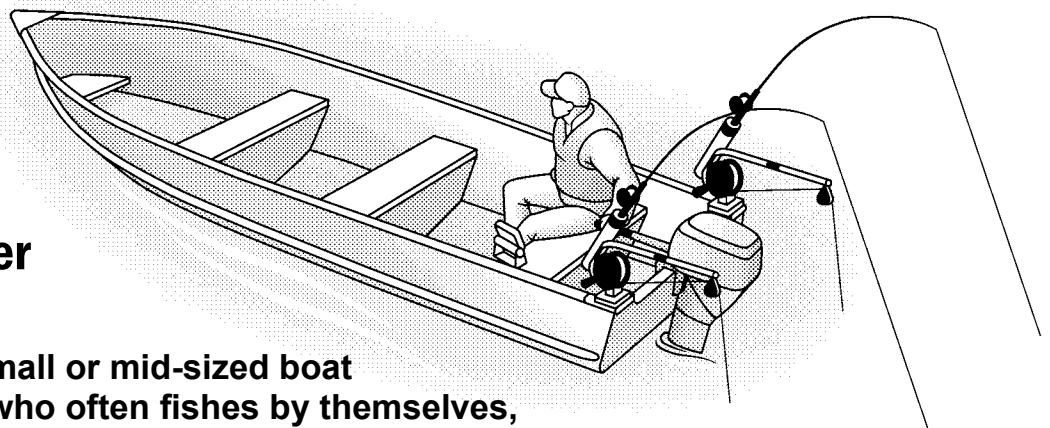

Downriggers Mounted Amidship On A Tiller Steered Boat...

Another popular layout for tiller boats is to mount the downriggers amidship. This allows easy access for both the person piloting the boat and for a second fisherman seated forward in the boat. Note that the sides of the boat keep the downrigger cables and fishing lines well clear of the motor's propeller. A pair of pedestal mounts will allow the downriggers to clear the boat's gunwales. Adding swivel mounting bases will make docking your boat easier.

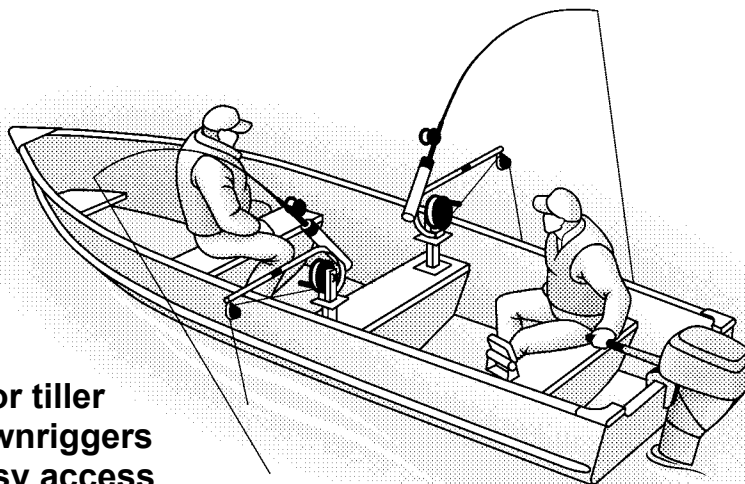

On larger console style boats that will accommodate a larger fishing party, you have more opportunity to run larger lure presentations. However, the same considerations given to a small boat hold true. All equipment should be accessible to all of the fishing party.

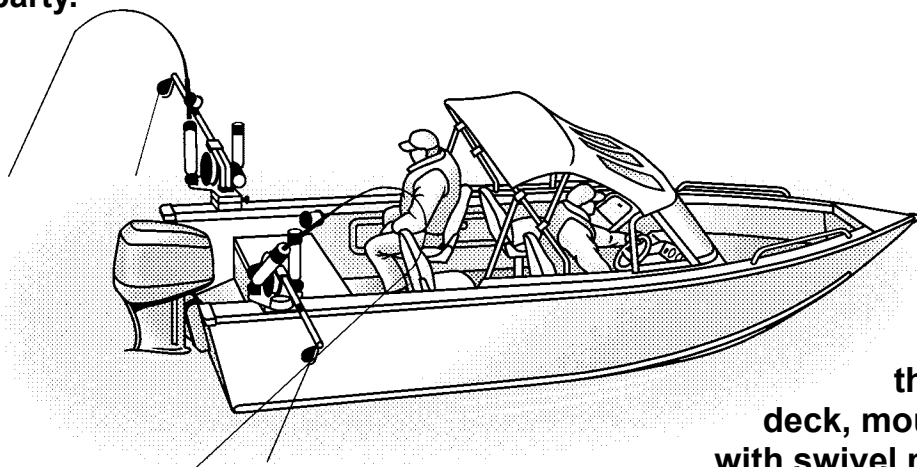

Downriggers For A Boat With Console Steering...

For boats (16 foot or larger) that have a four inch gunwale deck, mounting a pair of downriggers with swivel mounting bases just forward of the motor well is a common practice. This location makes setting lines easy and safe. (The swivel mounting base allows you to spread your lure presentation over a wider area when fishing and turn the downriggers in line with the boat for docking and trailering.)

Four Downriggers For A Large Lure Presentation...

Cover more water to catch more fish.

Charter captain's and tournament pros increase the chances for a successful fishing trip by increasing the number of lures in their presentation. By mounting two downriggers on the transom and two downriggers on swivel mounting bases on the gunwale decks, you can control the position of your lure presentation.

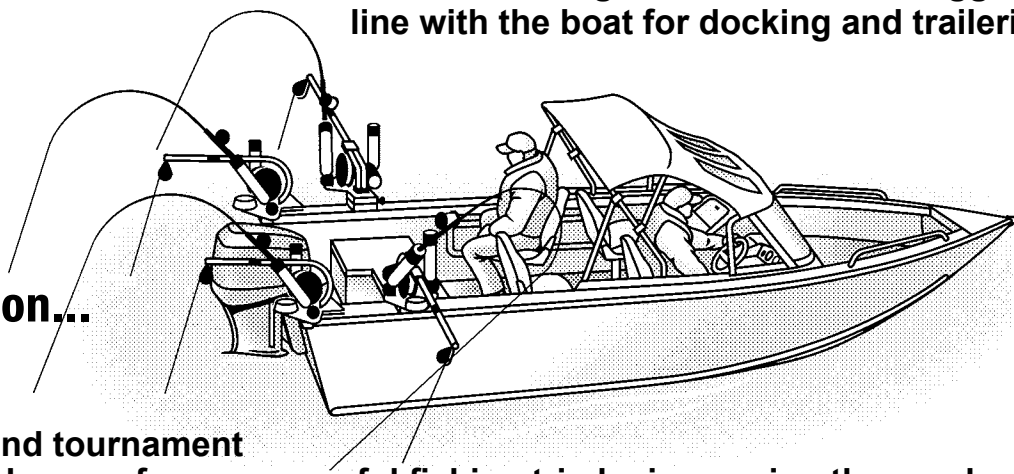

Transom Bars Add Versatility To Your Boat...

Big Jon Sports® builds heavy-duty transom bars that are pre-drilled and tapped to accept four Big Jon Sports® downriggers. The whole assembly of transom bar and downriggers can easily be installed or removed as one unit.

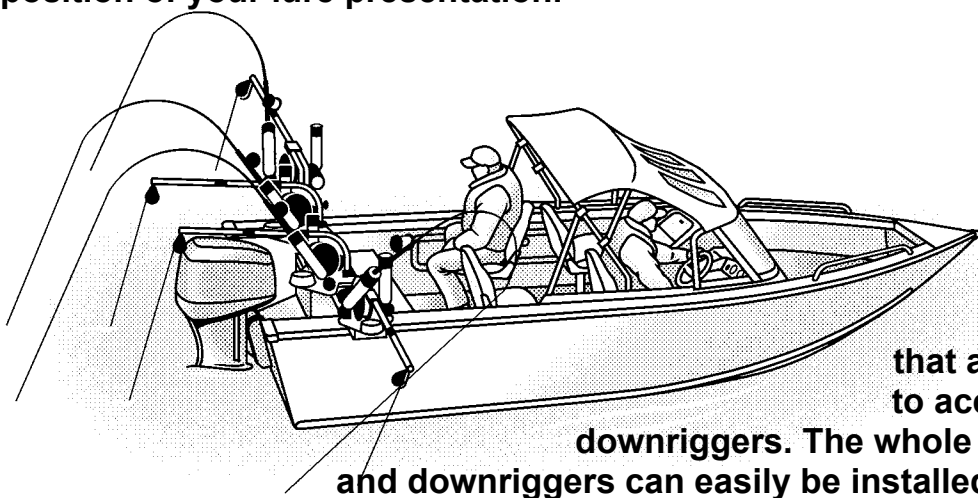

A Planer Rigger Mounted On The Bow Of A Tiller Steered Boat...

The bow deck of a tiller boat is the ideal location for mounting a planer mast. When installing a planer rigger system, remember two important facts.

First, the taller your mast is, the greater the distance your planers will travel from the sides of your boat.

And second, the farther forward you mount the mast, the less distance your planers will travel behind your transom.

Both points effect handling and control.

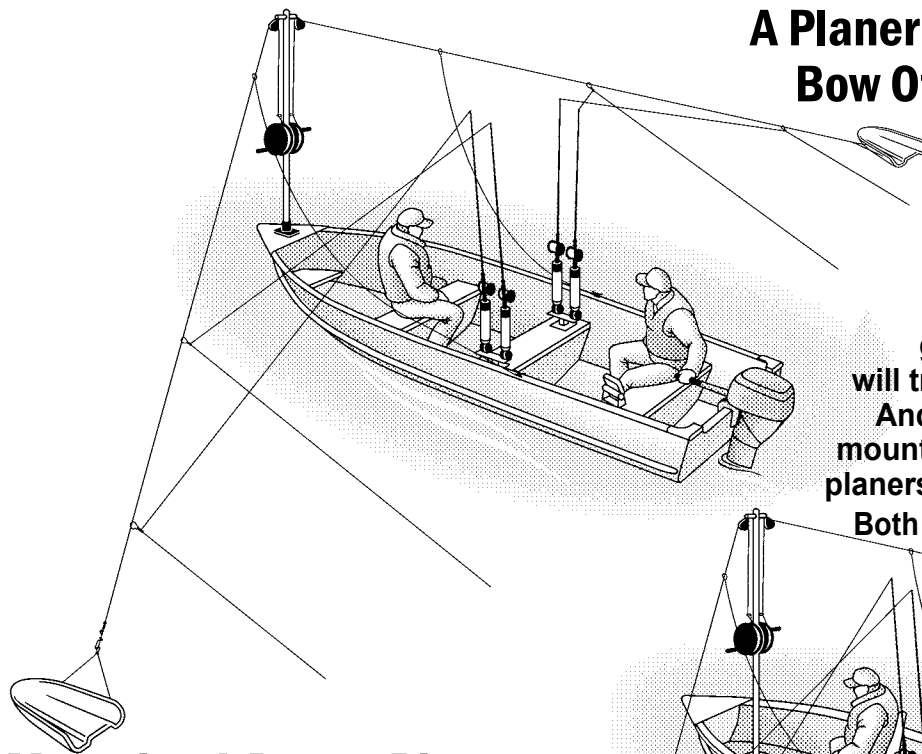

Mounting A Planer Rigger In A Pedestal Seat Base...

Many fishermen choose to adapt their planer mast so that it will fit into the base of the pedestal seat at the bow of their boat.

The Big Jon Sports® Service Department can custom build a Pedestal Seat Adapter for some styles of pedestal seats on the market, just call: (231) 275-1010 or go on-line, to the Service page of our website...

www.bigjonsports.com

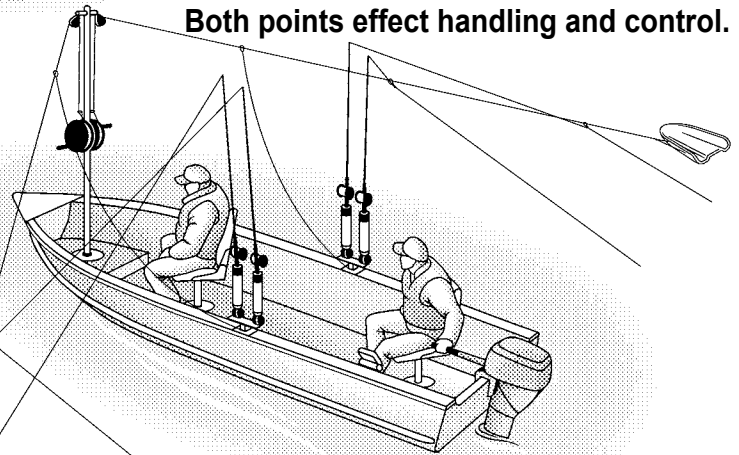

Planer Riggers For Boats With Console Steering...

For larger boats, where the bow is not easily accessible, a pair of single reel planer masts mounted just behind the cabin or canopy is a popular solution.

The mast and tow lines are easy for all members of the fishing party to reach. You can also update your mast on the bow with a pair of electric reels, which are remotely controlled from the steering console.

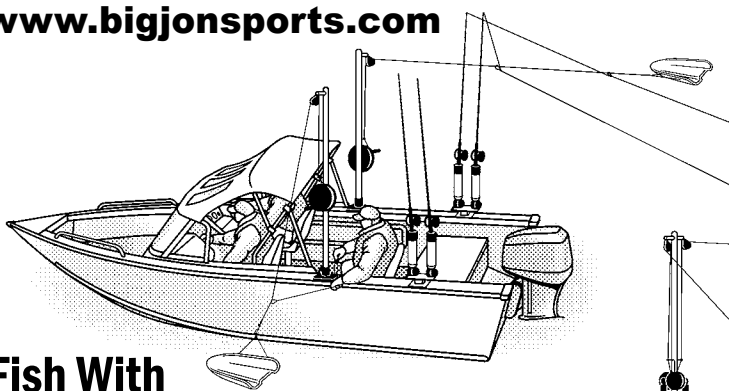

Fish With The Big Jon Sports® Otter® Boat...

The Otter® Boat was designed to achieve a greater distance from your boat than the old fashion boards or skis. It handles rough water well and won't stall in turns.

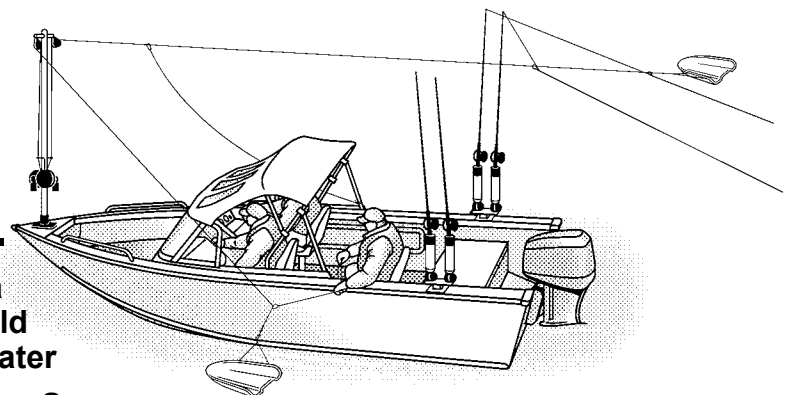

Installing Big Jon Sports® Trolling Equipment

Mounting The Big Jon Sports® Standard 4" x 4" Mounting Plate...

This mounting plate accepts all Big Jon Sports® downriggers and rod holders with 4" x 4" bases. It also accepts the Big Jon Sports® quick-slide and swivel mounting bases.

1. Make sure all electrical wiring below the mounting surface is clear of the area to be drilled.
2. Use the mounting plate as a template to locate and mark the hole.
3. Drill the holes in the mounting surface and the backing board together.

Note: The use of a backing board is recommended to distribute the stress load over a larger surface for greater strength.

4. Bolt the mounting plate and the backing board to the mounting surface with flat washers and nuts (as shown in the illustration).

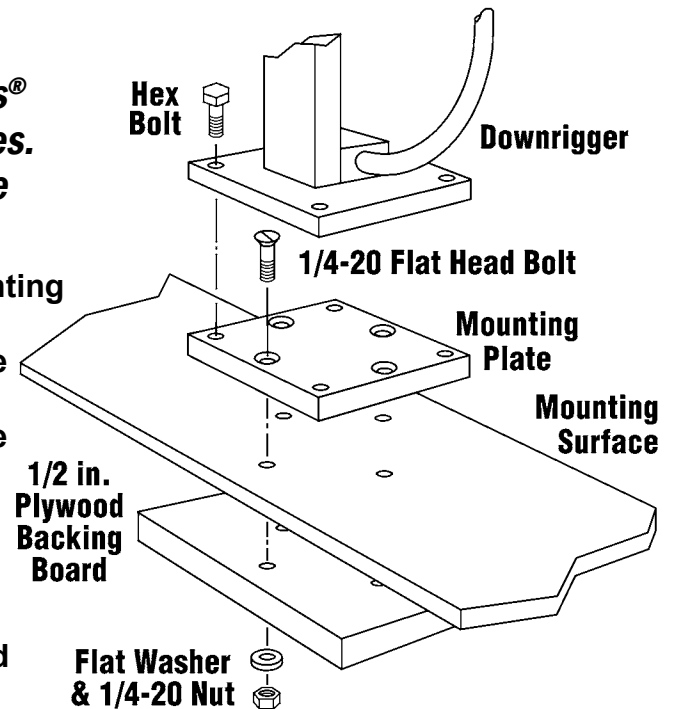

Mounting The Big Jon Sports® Slim-Line Mounting Channel...

This mounting channel accepts the Gadabout® downrigger with slim-line base and the single Multi-Set® rod holder

1. Make sure all electrical wiring below the mounting surface is clear of the area to be drilled.
2. Use the mounting channel as a template to locate and mark the hole.
3. Drill the holes in the mounting surface and the backing board together.

Note: The use of a backing board is recommended to distribute the stress load over a larger surface for greater strength.

4. Bolt the mounting channel and the backing board to the mounting surface with flat washers and nuts (as shown in the illustration).

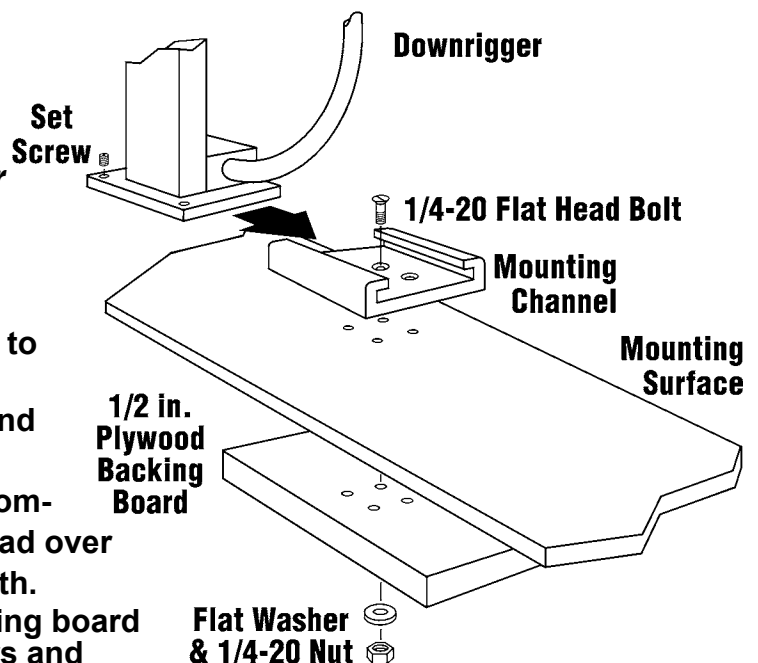

Mounting The Big Jon Sports® Standard Planer Rigger Base...

*This cast aluminum base accepts all Big Jon Sports®
planer masts and the Multi-Set® rod holder tree.*

1. Make sure all electrical wiring below the mounting surface is clear of the area to be drilled.
2. Use the mounting base as a template to locate and mark the hole.
3. Drill the holes in the mounting surface and the backing board together.

Note: The use of a backing board is recommended to distribute the stress load over a larger surface for greater strength.

4. Bolt the mounting base and the backing board to the mounting surface with flat washers and nuts (as shown in the illustration).

Assembling The Planer Rigger:

5. Insert the lower mast section into the mounting base and secure with the 1/2-20 hex bolt.
6. Slide the upper mast and reel assembly onto the lower mast and secure with the 5/16-18 bolt and acorn nut.
7. If the electric planer reels are to be installed, mount them to the lower mast section, as close the base as possible. This will reduce the stress applied to the mounting surface. Then connect the wiring as describe on page 8.
8. Thread the tow line through the pulleys as described on page 7.

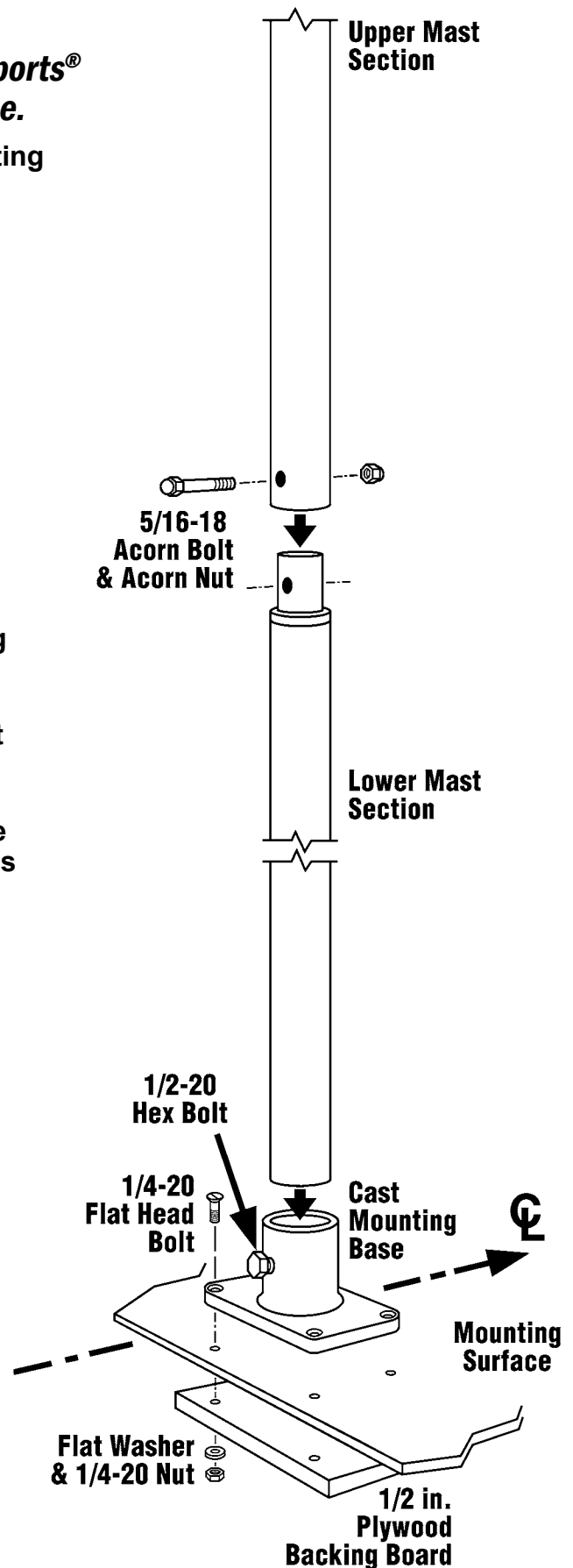

Assemble The Captain's Pak[®] Tip-Up Boom To The Downrigger Base...

1. Slide the double rod upper arm assembly (A) onto the lower hinge assembly (B).
2. Line up the holes and insert the hinge pin (C).
3. Hold the hinge pin in place by fitting the retainer clip (D) into the groove on the end of the hinge pin.
4. Screw the boom sections (E) into the rod block on the double rod upper assembly.
(See page 7 for boom assembly instructions.)

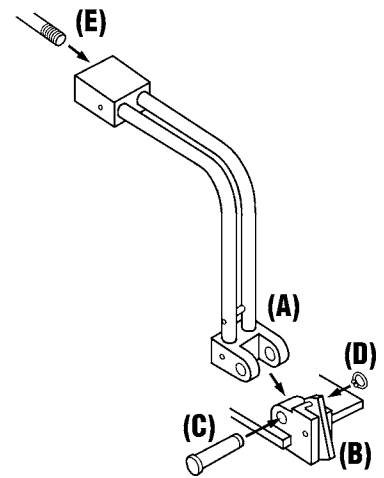

Mounting The Multi-Set[®] Rod Holders To The Ball Cradle Cannonball Holder...

1. Mount the Multi-Set[®] rod holders to the ball cradle using the 3/8 inch nuts and lock washers that are provided with the rod holders.
2. Rotate the rod holders to your desired position before securing (as shown in the illustration). Lock the rod holder in place with the set screw, using a 1/8 inch Allen wrench.

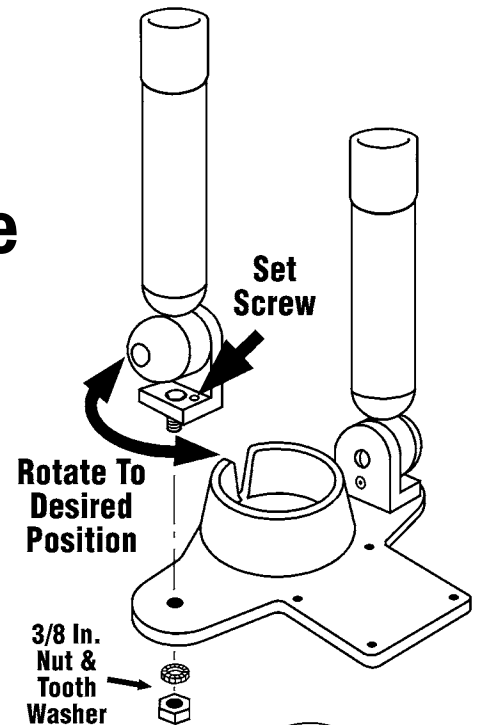

Mounting The Downrigger And Ball Cradle To The Mounting Plate...

1. Position the ball cradle over the mounting plate that has been installed on the mounting surface. Then position the downrigger base over the ball cradle.
2. Fit one of the 1-1/8 inch hold down bolts through the downrigger base and ball cradle. Locate the threaded hole in the corner of the mounting plate. Screw in the first hex bolt, leaving it untightened.
3. Locate the remaining three hex bolts in the same manner. Finally, tighten all four hex bolts firmly.

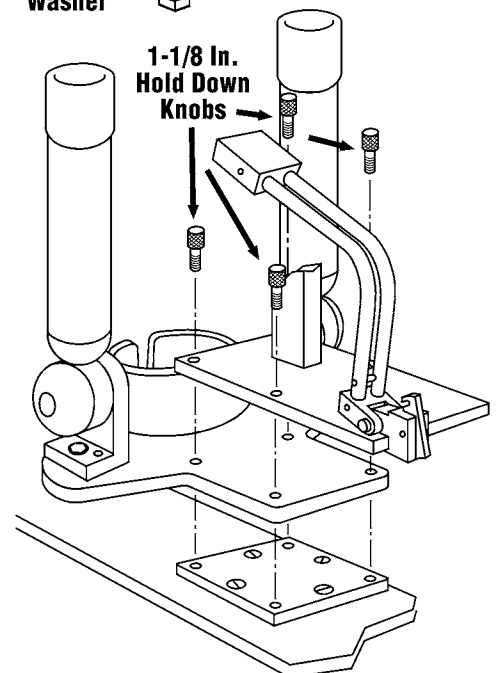

Assemble The Downrigger Boom...

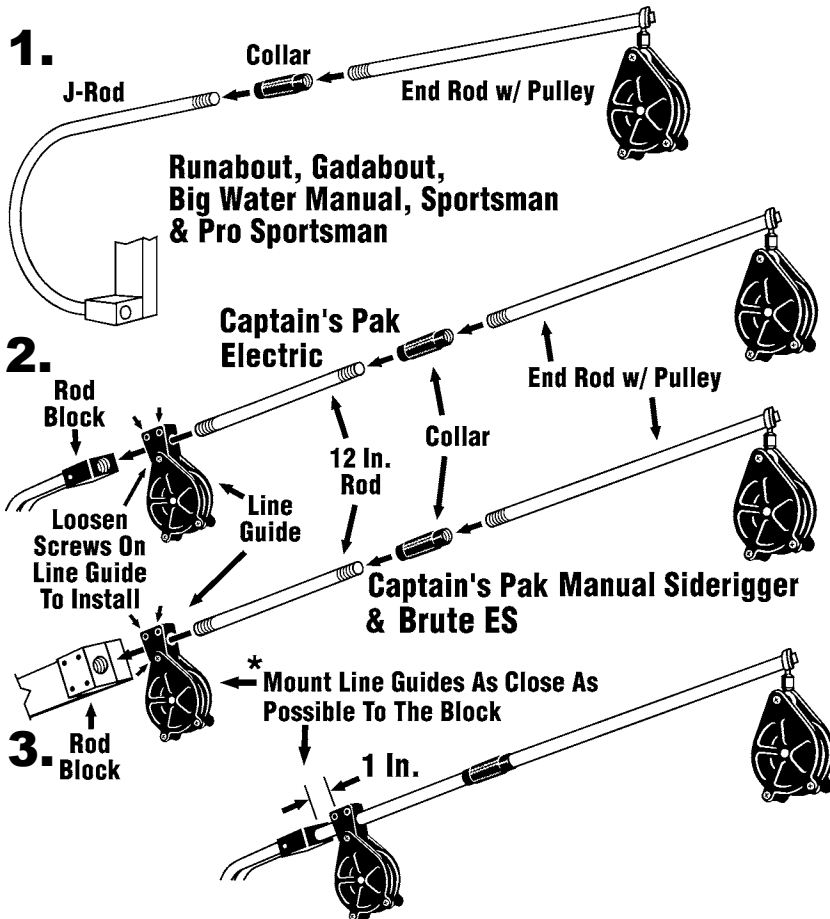

1. For J-rod style downriggers, firmly screw the collar onto the threaded end of the J-Rod. Then firmly screw the threaded end of the end rod and pulley assembly into the other end of the collar.
2. For downriggers with tip-up booms, start by loosening the (3) screws that hold together the line guide hanger. Thread the 12 inch rod section through the line guide. Then firmly thread the 12 inch rod into the rod block (found on the tip-up assembly). Position the line guide on center with the downrigger reel and one inch ahead of the rod block. Then tighten the (3) screws on the line guide to secure it in position.
3. Next, firmly screw the collar onto the 12 inch rod. Then firmly screw the end rod and pulley assembly into the collar.

* Locating the line guide close to the reel helps load the cable uniformly.

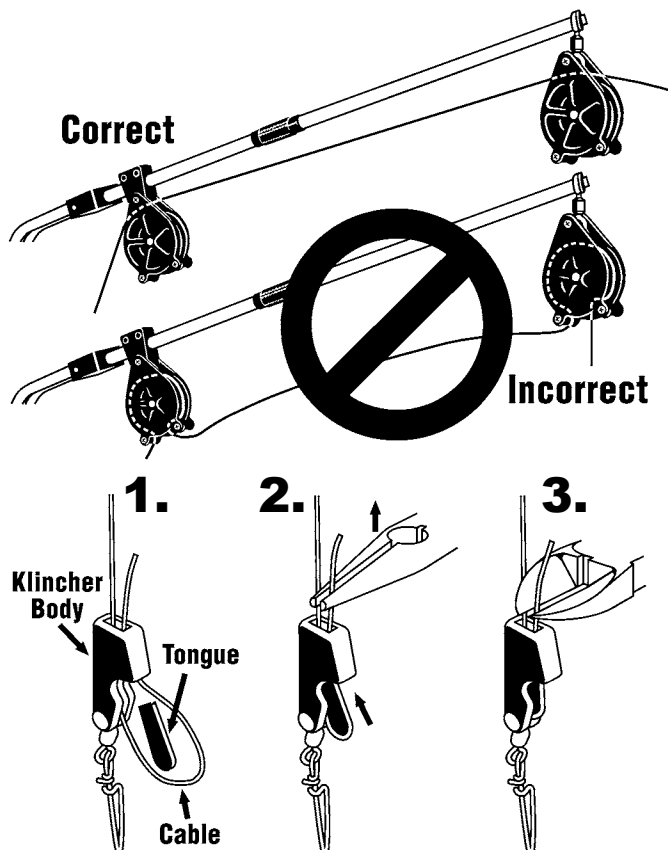

Threading The Cable And Installing The Klincher...

To thread the downrigger cable, start by releasing the tension on the downrigger reel by loosening the clutch knob. Then pull a length of cable from the reel. Thread the cable over the top of the wheels of the line guide and tip pulley (as shown in the top illustration). **DO NOT THREAD THE CABLE FROM THE BOTTOM OF THE LINE GUIDE OR TIP PULLEY!**

This will cause the cable to damage the pulley.

To Install The Klincher With Swivel Clip:

1. Feed the cable into the top of the Klincher body and out the side. Bring the cable around the tongue, back into the side of the Klincher and out through the top.
2. Insert the tongue into the side of the Klincher and seat the tongue in place by pulling the cable from the top with pliers.
3. Trim the cable end with wire cutters.

Electrical Hook-Up For Downriggers And Planer Reels...

1. Captain's Pak®, Pro Tournament and Sportsman:

Connect the installation wire to the battery or buss bar. The **Blue** wire connects to the **POSITIVE** post (+). The **Brown** wire connects to the **NEGATIVE** post (-). Plug the male connection of the wire from the downrigger into the female connection of the of the installation wire.

Note: For the Captain's Pak®, Sportsman and Pro Tournament, use #10 AWG (American Wire Gauge) to connect the battery to the buss bar.

2. Brute ES:

WARNING!

To assure the validity of your warranty:

You **MUST** use a Buss Bar between your battery and your downrigger or use the **ConnectPro® Plug and Receptacle Set**.

Always wire POSITIVE (WHITE) to POSITIVE and NEGATIVE (BLACK) to NEGATIVE as shown in the illustration to the right...

When wiring the plug and receptacle, leave one prong unwired (This prong will serve as a locator prong and assure that your downrigger's electrical circuit is always wired for the correct polarity).

Next, Match and attach the **POSITIVE (WHITE)** wires to the corresponding prongs of the plug and receptacle. Then match and attach the **NEGATIVE (BLACK)** wires to the corresponding prongs of the plug and receptacle.

TIP: Take time to make sure that all plugs, receptacles and downriggers are wired identically, so all downriggers are interchangeable on your boat.

3. Electric Planer Riggers & Planer Reels:

Mount the remote switches in the location on your boat that you want to operate your planer riggers (or reels) from. Feed and mount the power cords along the deck or gunwale to the planer rigger (or reels).

Connect the 20 foot power cords to the butt connectors on the motor. The **WHITE** wire (+) of the power cord connects to **RED** wire on the motor. The **BLACK** wire (-) of the power cord connects to the **BLACK** wire on the motor. Crimp the butt connectors to secure the wires. Next, connect the installation wire (with the female end) to the battery or buss bar. The **BLUE** wire (+) connects to the **POSITIVE** post. The **BROWN** wire (-) connects to the **NEGATIVE** post. Then plug the male and female ends together.

Note: For the The Electric Planer Riggers and Electric Reels, use #10 AWG (American Wire Gauge) to connect the battery to the buss bar.

Warning: Always disconnect the battery from the buss bar before starting any installation.

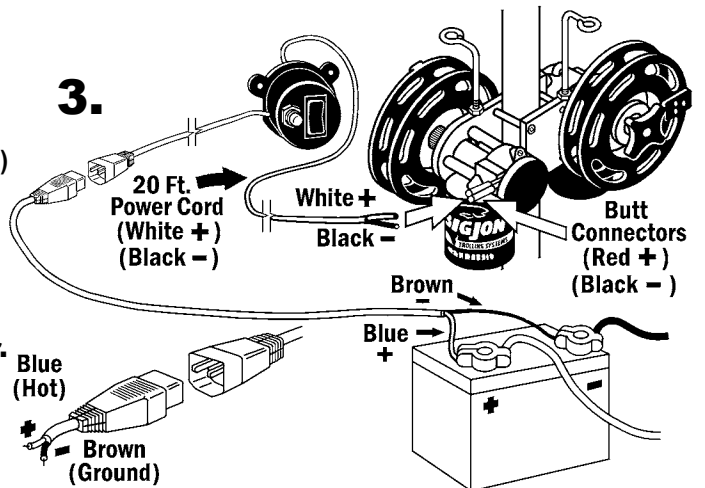
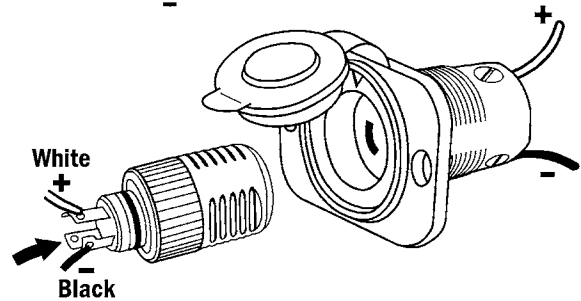
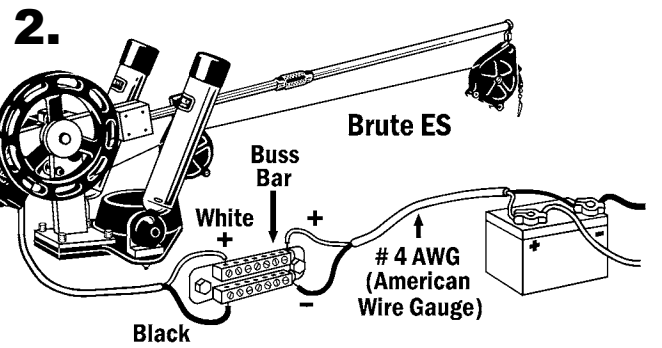
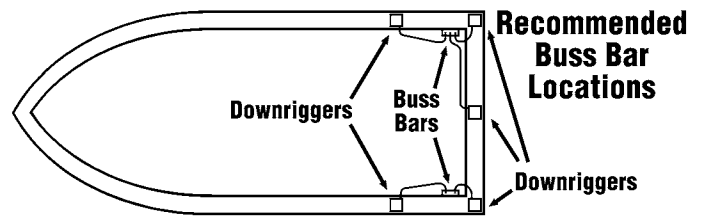
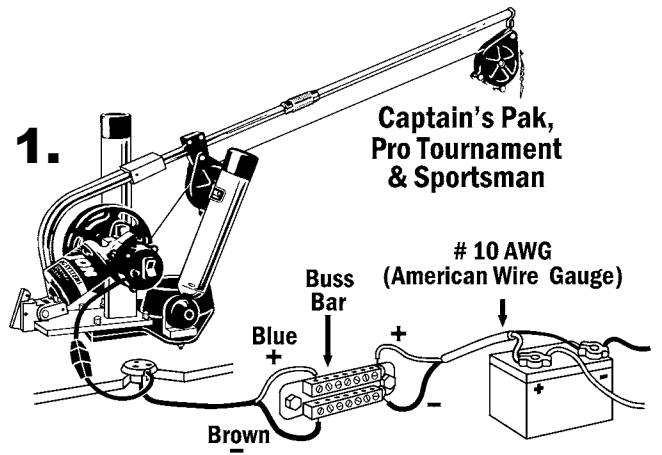

Installing The Auto-Stop System...

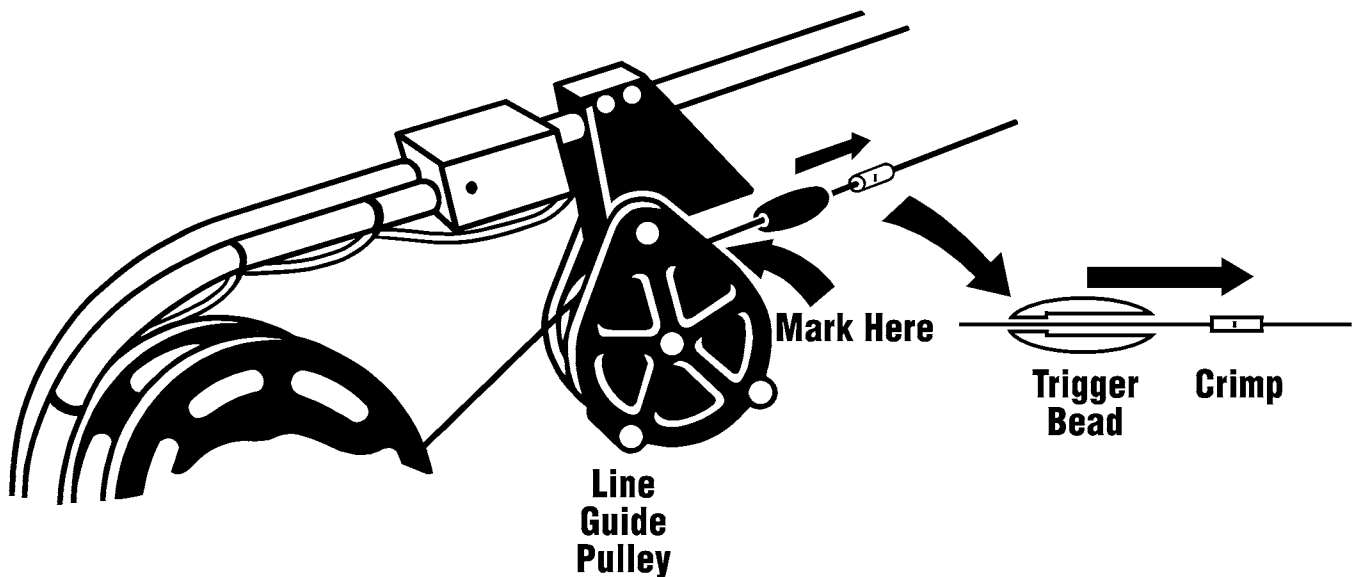

1. Slide the Trigger Bead onto the downrigger cable (small hole towards the motor) . Then slide the crimp onto the downrigger cable. Feed the cable through the Line Guide and Tip Pulley and attach the Klincher to the end of the cable (as shown on page 7).
2. Mount the downriggers on your boat and attach the line release and cannonball. Lower the cannonball to just below the water line of the boat.
3. Use a felt marker to mark the cable just ahead of the line guide pulley. Then, let out about one foot more cable and slide the Crimp up to the place that you marked the cable.
4. Crimp the Crimp securely at that location and slide the Trigger Bead over the Crimp.

Setting The Auto-Stops Shut-Off Depth...

When you locate the Trigger Bead, we recommend that you set it to shut off the downrigger motor when the cannonball is at a depth of 6 to 8 inches below the surface.

If you set to shut off when the cannonball is at the surface, you run the risk of having the cannonball swing into the side of your boat when you are fishing in rough water.

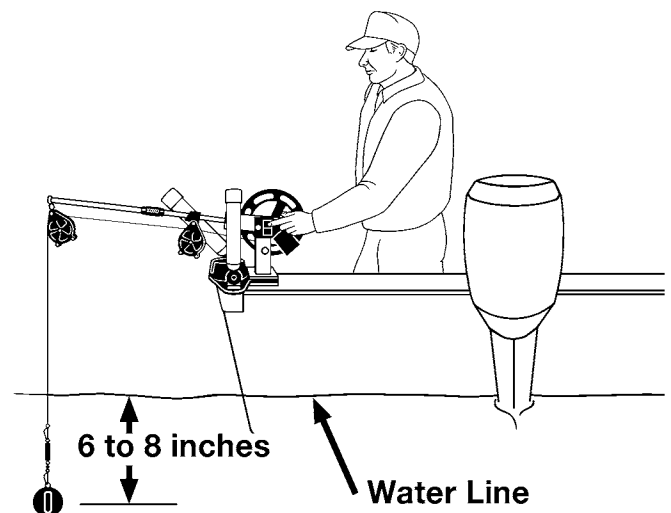

Adjusting Your Multi-Set® Rod Holders

1. Firmly grasp the lower end of the rod holder tube and pull the spring loaded dome away from the locking pin of the upright base.

1.

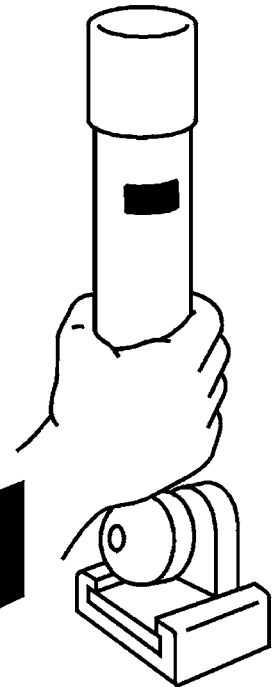

2. Rotate the rod holder tube to any of the seven locking positions in the spring loaded dome.

2.

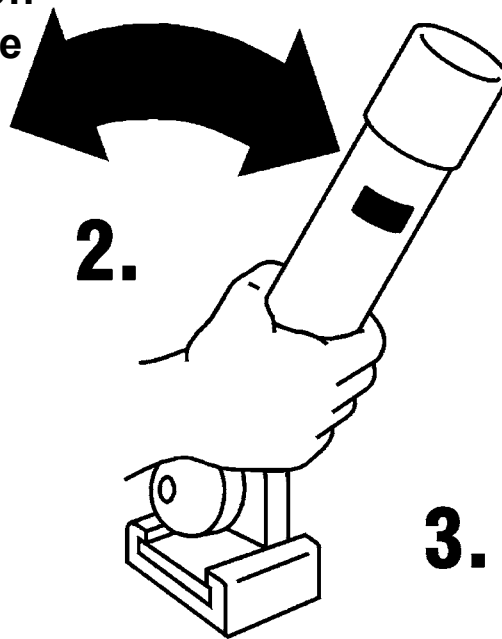

3.

3. Release the rod holder tube and let the locking pin in the upright base to set into the desired locking hole of the spring loaded dome.

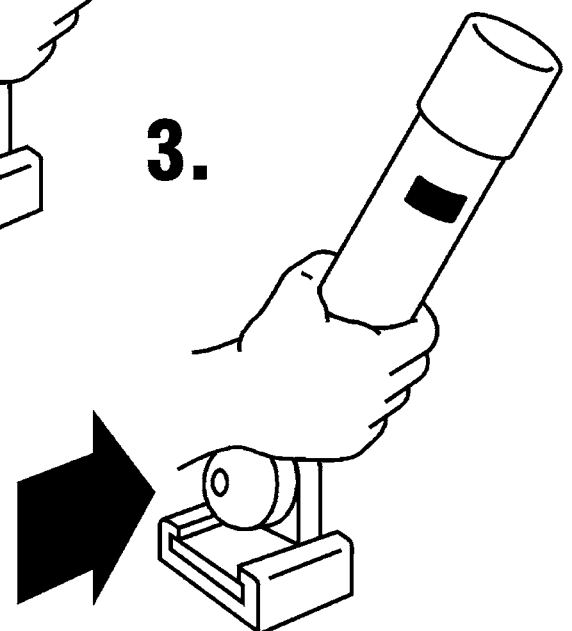

Adjusting Your Multi-Axis II Rod Holder

To adjust on the horizontal axis...

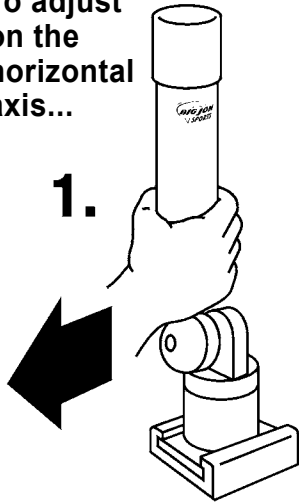

1. Pull the rod holder away from the upright pedestal

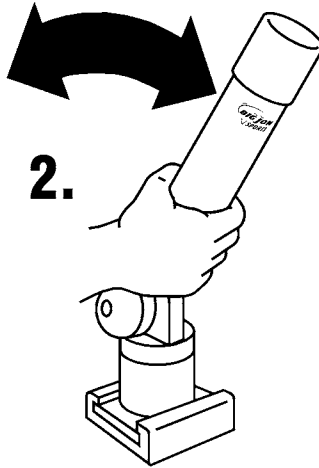

2. Rotate the rod holder to the angle you want

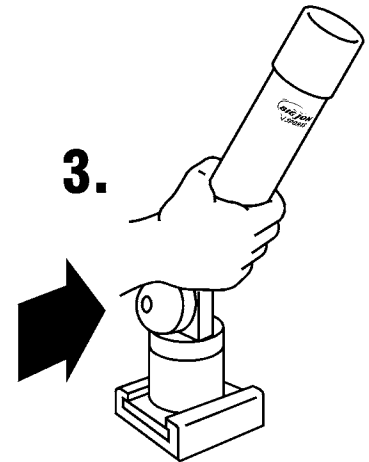

3. Release the pressure on the rod holder and let the internal spring lock it into the nearest locking position

To adjust on the vertical axis...

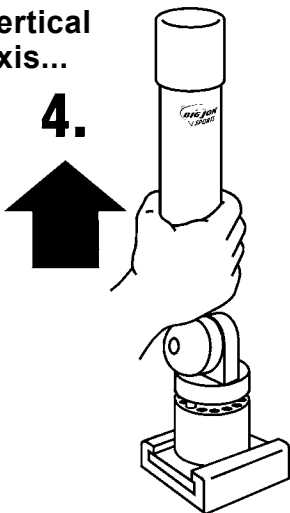

4. Pull the rod holder up from the pedestal

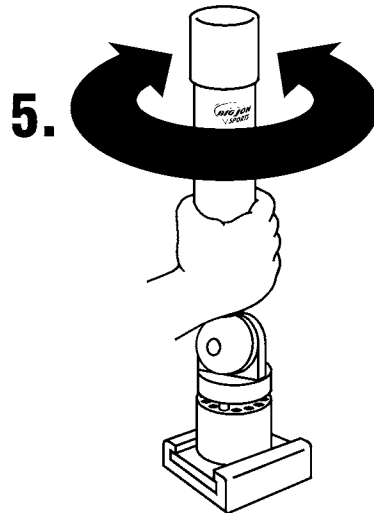

5. Rotate the rod holder to the direction you want

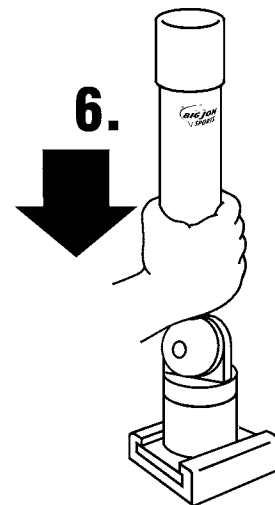

6. Release the pressure on the rod holder and let the internal spring lock it into the nearest locking position

Operating Your Ratcheting Diver Rod Holder

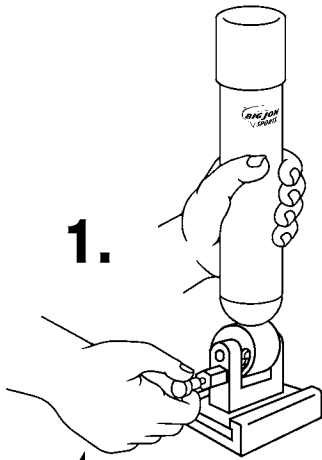

1. Pull the latch pin away from the upright pedestal

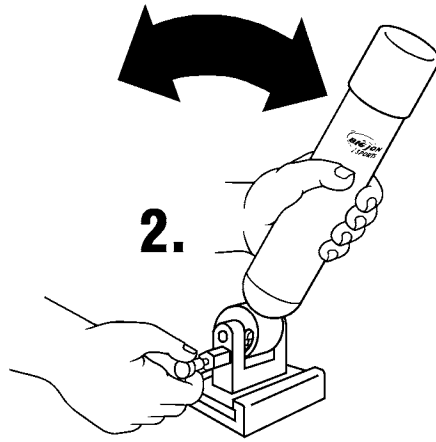

2. Rotate the rod holder to the angle you want

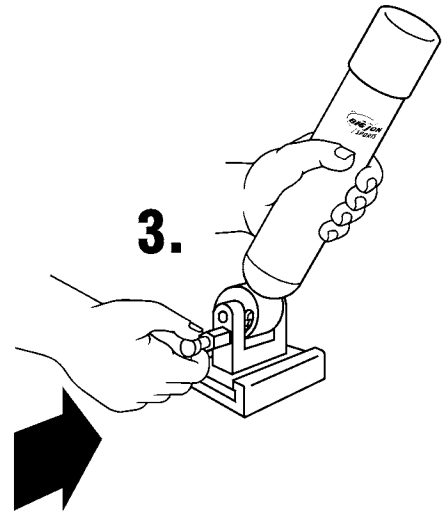

3. Release the pressure on the latch pin and let the internal spring lock it into the nearest locking position

4. When a fish bites and you grab your fishing rod, the Ratcheting Diver Rod Holder will return to the vertical position and lock in place.

This rod holder design eliminates the need to reach out over the side of the boat, making it easy and safe.

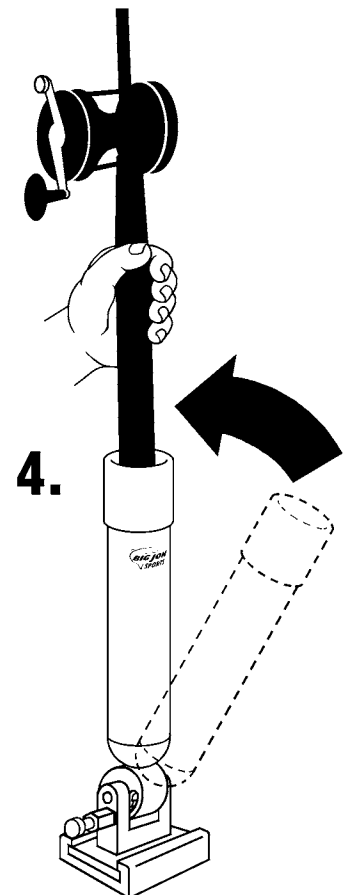

Adjusting Your Quik-Draw Rod Holder

To adjust on the horizontal axis...

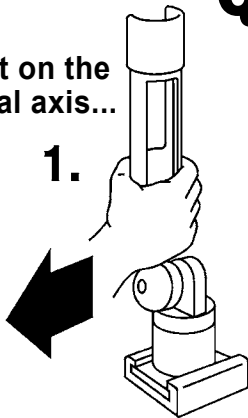

1. Pull the rod holder away from the upright pedestal

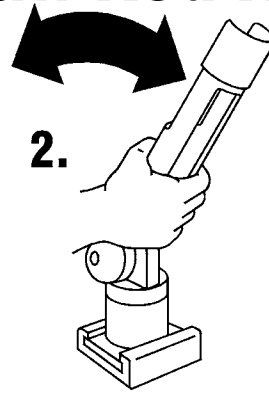

2. Rotate the rod holder to the angle you want

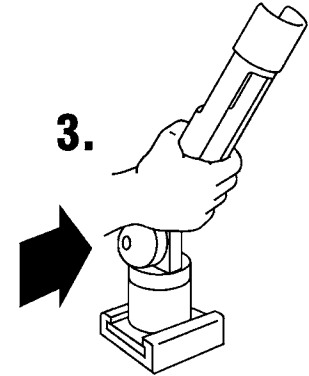

3. Release the pressure on the rod holder and let the internal spring lock it into the nearest locking position

To adjust on the vertical axis...

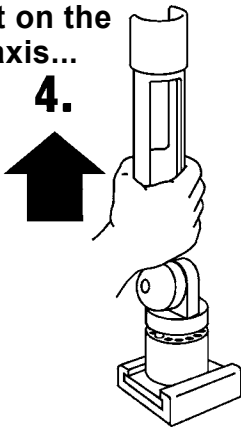

4. Pull the rod holder up from the pedestal

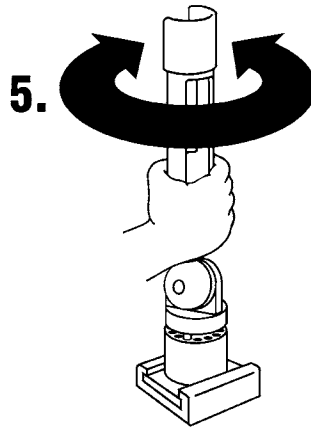

5. Rotate the rod holder to the direction you want

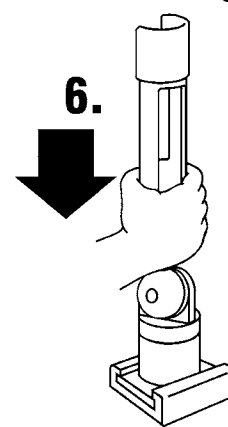

6. Release the pressure on the rod holder and let the internal spring lock it into the nearest locking position

7. Place your fishing rod into the rod holder with the handle all the way into the bottom of the rod holder

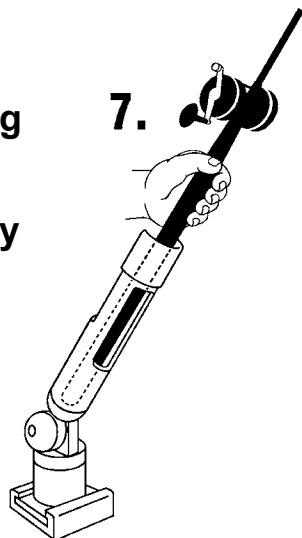

8. When you lift your rod out of the rod holder the rod handle will clear the rod holder through the cut-away bottom

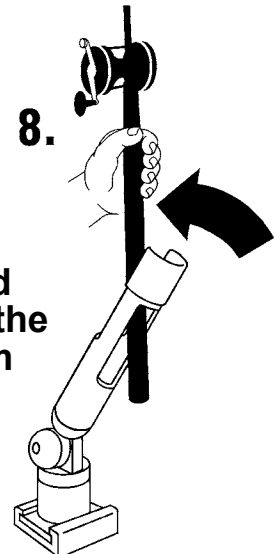

Assembling Your Otter Boat®

1. Mount the keel to the Otter Boat® by inserting the two 1/4-20 bolts from the bottom, through the keel and then through the Otter Boat®. Then tightly secure the bolts with the washers and wing nuts from the top of the Otter Boat®.

Note: Mount the keel on the opposite side of the Otter Boat® from the tow line, with weight pointed away from the tow line.

2. Tie a loop (off center) in the tow line with one end approximately 5 inches longer than the other end.
3. Mount tow line to the Otter Boat® by threading it through the holes on the opposite side from the keel. Tie a knot in each end of the tow line, so the loop is approximately 9 inches from the front hole and approximately 14 inches from the rear hole.

Note: You can fine tune the way your Otter Boat® tracks in the water by adjusting the length of either or both of the tow lines.

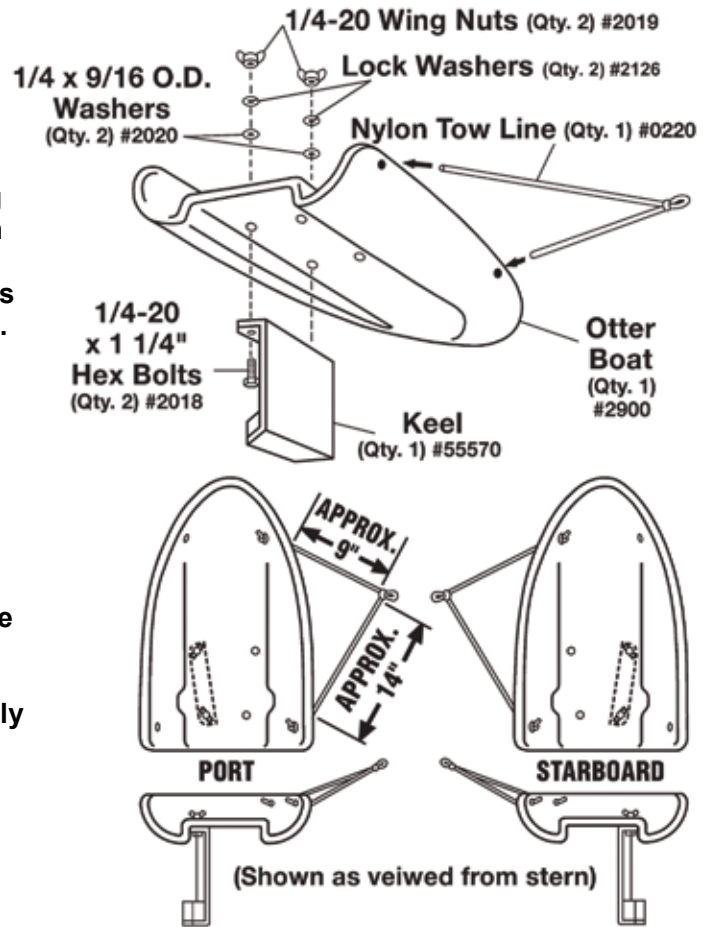

How To Modify Your Otter Boat® For Special Applications...

(Pull Copper Wire, Lead-Core & Heavy Lures)

1. Contact Big Jon Sports® to purchase a "1/2 Weight Keel", **Part # 55573**
2. Disassemble your Otter Boat® (except for the existing keel).
3. Insert a 1/4-20 bolt into the rear hole of your new 1/2 Weight Keel and the rear hole in the Otter Boat®. Make sure the keel weights are pointed in the same direction.
4. Rotate the front of the 1/2 Weight Keel until it is parallel to the existing keel. Then mark the front hole of the 1/2 Weight Keel on the bottom of the Otter Boat®.
5. Remove the 1/2 Weight Keel and drill the new hole using a 1/4 inch diameter drill bit.
6. Reassemble your Otter Boat® (except for the tow line).
7. On the side of the Otter Boat® that you removed the tow line from, mark the locations for two new holes one inch below the existing tow holes.
8. Drill the new tow line holes using a 3/16 inch drill bit. Then reinstall the tow line.

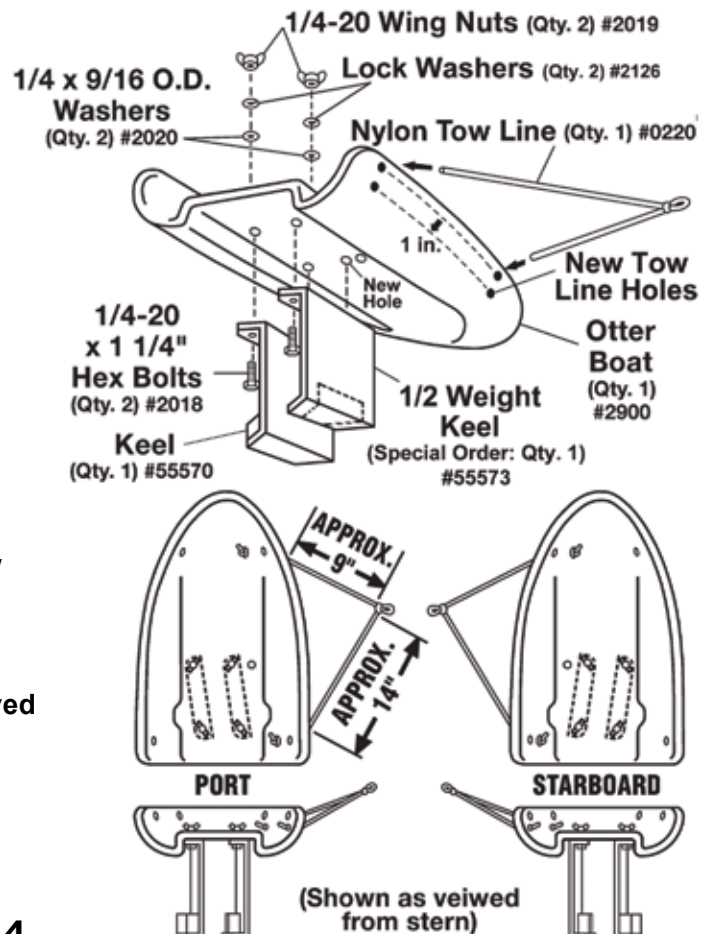

Operating Your Manual Downrigger

Step-By Step Instructions For: The Gadabout®, Runabout® And Big Water Manual Downriggers...

1. While the boat is moving at trolling speed, set your fishing reel to free-spool, apply slight pressure to the spool with your thumb and let your lure to the desired distance behind the boat. Then set the drag clicker to stop your reel from free-spooling. Place your rod in the rod holder.

2. To place the line in the line release (the Band Buster® which comes with your downrigger is shown here), grab the fishing line and wrap a rubber band around the line and back through itself. With the other hand reach down and firmly take hold of the line release. Lift the cannonball out of the water and hook the rubber band to the line release. Then ease the cannonball back into the water. **(Read more about line releases on pages 21 and 22.)**

3. While firmly gripping the downrigger reel's handle, loosen the clutch knob (found on the left side of the downrigger) by turning the clutch knob counter-clockwise. This will release the tension on the disc clutch plates that hold the cannonball at a given depth.

4. When you feel the weight of the cannonball pull on the reel, turn the reel counter-clockwise to lower the cannonball. Watch the depth counter that is mounted on the top of the downrigger's upright. The depth counter is marked in one foot increments.

Note: At the initial installation of your downriggers, hold the counter wheel firmly at zero and raise or lower the cannonball to the surface to set the depth counter. This will ensure that your depth counter is showing the depth of the cannonball.

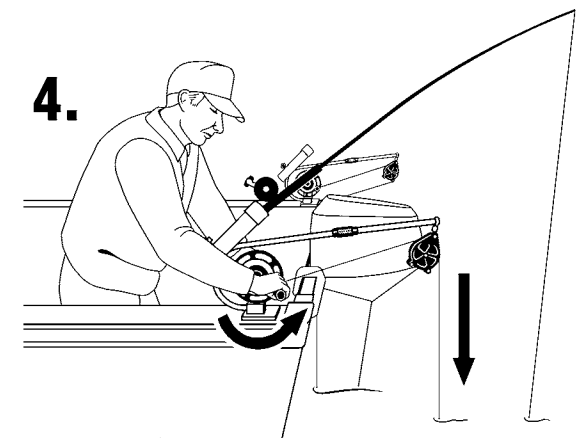
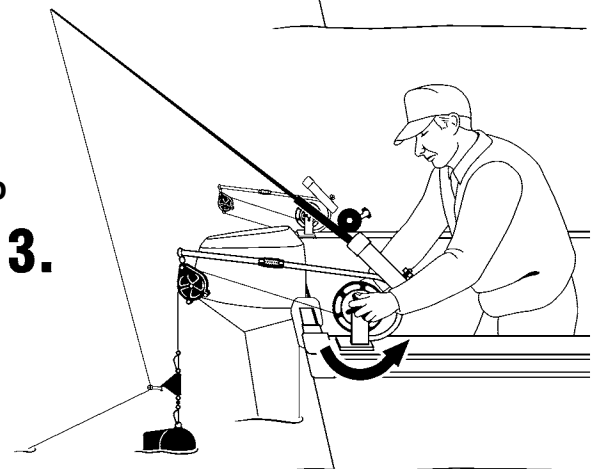
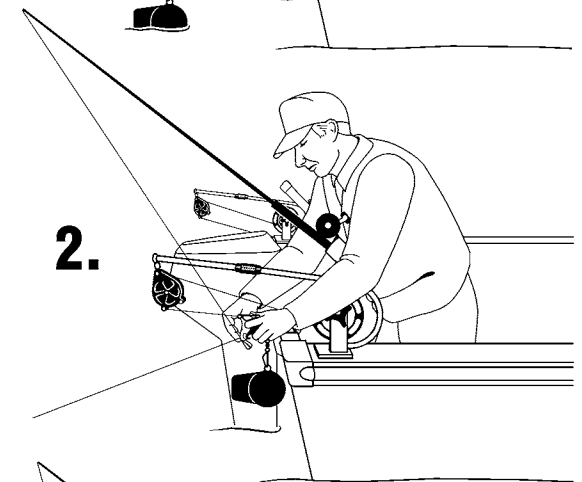
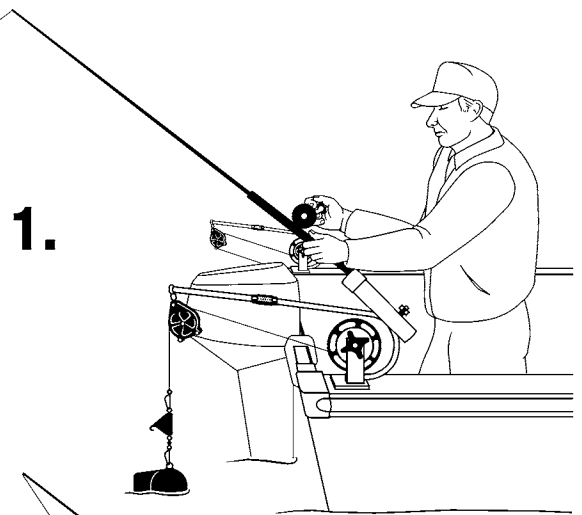

5. After you see the depth you desire marked on the depth counter, retighten the disc clutch by turning the clutch knob clockwise until the clutch holds the cannonball.

Note: You may choose to set the clutch to act like the drag on your fishing reel and it will give cable if your cannonball becomes obstructed. Or you may tighten it down securely, which is recommended when fishing in rough water.

6. Once you've set the clutch on your downrigger, set the drag and drag clicker on your fishing reel. Then take up the slack in your fishing line, until there is a bow in your fishing rod.

Tip: (One of the virtues of using a Band Buster® release is that when a fish strikes and pulls against the rubber band, the rod tip will start bouncing and signal the strike.)

7. When a fish strikes your lure or when you want to retrieve your lure, remove your fishing rod from the rod holder and abruptly lift your fishing rod to break the rubber band. Then fight and land your fish or retrieve your lure.

Note: A newcomer to downrigger fishing may feel compelled to have their fishing partners raise the other cannonballs and retrieve the fishing lines, when a fish is "On". This is not necessary! Maintain your trolling speed and direction while you fight the fish from the back of the boat. Keeping the fish clear of your other lines is easier than you would think.

8. Finally, when you are ready to quit fishing or want to change lures, loosen the clutch loosen the clutch knob as you did in Step 3 and retrieve the cannonball by turning the downrigger reel clockwise until the cannonball surfaces. Then tighten the clutch knob to hold the cannonball securely.

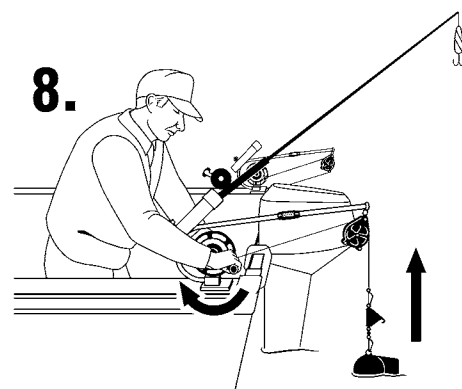
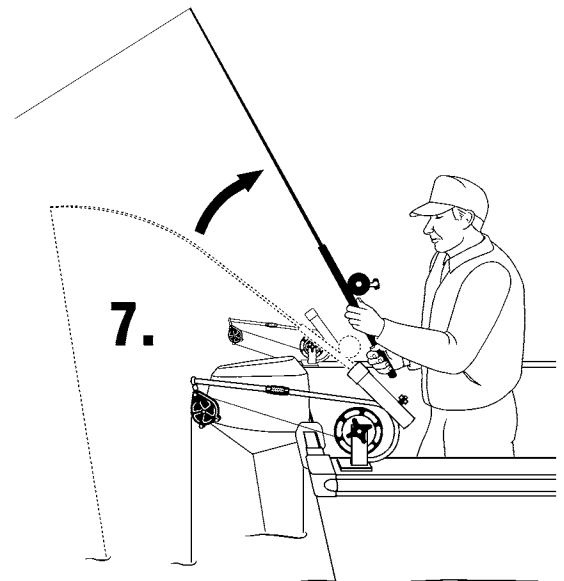
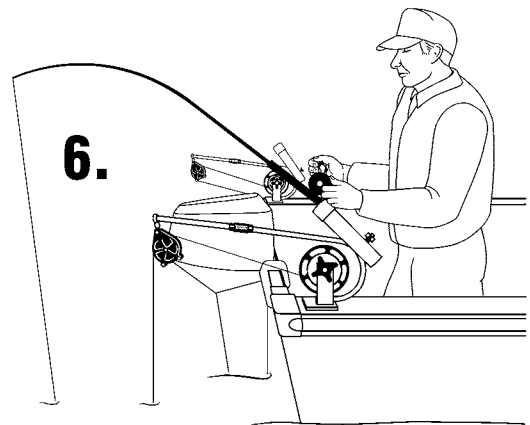
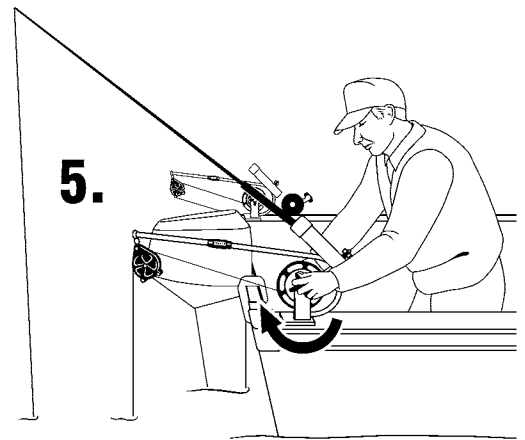

Operating Your “One-Hand-Crank” Manual Siderigger...

1. While the boat is moving at trolling speed, set your fishing reel to free-spool, apply slight pressure to the spool with your thumb and let your lure to the desired distance behind the boat. Then set the drag clicker to stop your reel from free-spooling. Place your rod in the rod holder.
2. With the tip-up boom locked in the vertical position and the cannonball in the Ball Cradle, place the line in the line release (the Band Buster® which comes with your Siderigger is shown here), by grabbing the fishing line and wrapping a rubber band around the line and back through itself. Then hook the rubber band to the line release. (**Read more about line releases on pages 21 and 22.**)
3. After removing the cannonball from the Ball Cradle and suspending it over the side of the boat, take a firm hold of the Tip-Up Boom with your right hand and release the Boom Latch Pin with your left hand. Then lower the cannonball into the water.
4. To lower the cannonball, “Ease” the crank handle counterclockwise until the reel starts to “slowly” slide and let out cable. Watch the depth counter that is mounted on the top of the downrigger arm. The depth counter is marked in one foot increments.

Note: At the initial installation of your downriggers, hold the counter wheel firmly at zero and raise or lower the cannonball to the surface to set the depth counter. This will ensure that your depth counter is showing the depth of the cannonball.

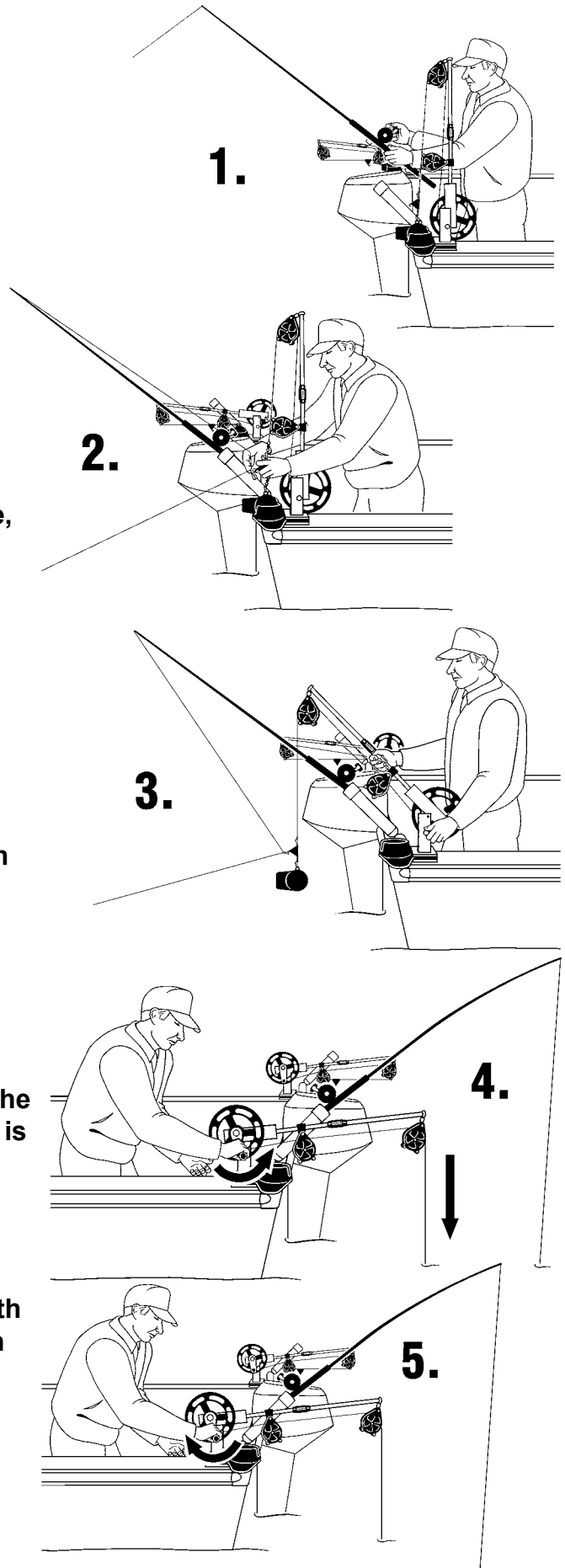

5. After you see the depth you desire marked on the depth counter, retighten the reel by turning the crank handle clockwise until the cannonball stops taking out cable.

6. Now hold onto the reel and continue to reel clockwise (about half a turn). This will secure the reel and prevent the cable from creeping out while you are trolling.

Note: You may choose to set the clutch to act like the drag on your fishing reel and it will give cable if your cannonball becomes obstructed. Or you may tighten it down securely, which is recommended when fishing in rough water.

7. Once you've set the depth of your cannonball, set the drag and drag clicker on your fishing reel. Then take up the slack in your fishing line, until there is a bow in your fishing rod. This will help signal a strike.

8. When a fish strikes your lure or when you want to retrieve your lure, remove your fishing rod from the rod holder and abruptly lift your fishing rod to break the rubber band. Then fight and land your fish or retrieve lure.

Note: It is not necessary to bring in the other fishing lines and raise the cannonballs when a fish is "On". This is not necessary! Maintain your trolling speed and direction while you fight the fish from the back of the boat. Keeping the fish clear of your other lines is easier than you would think.

9. When you want to retrieve the cannonball, turn the crank handle counter-clockwise until the cannonball surfaces.

10. Lift the Tip-Up Boom and place the cannonball in the Ball Cradle.

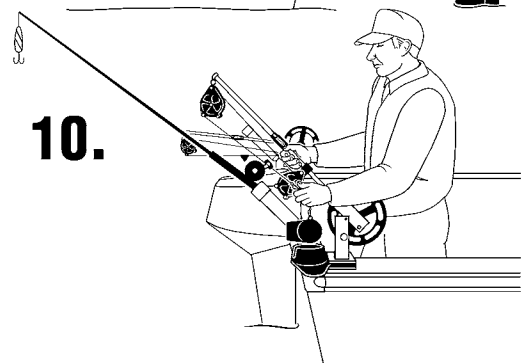
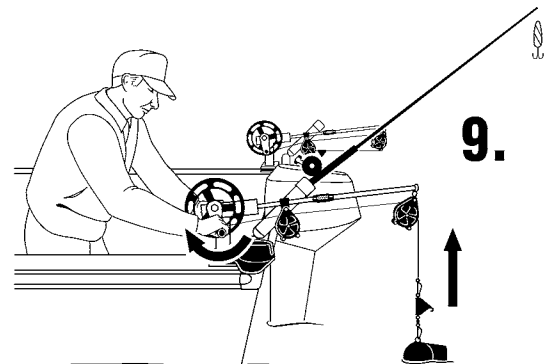
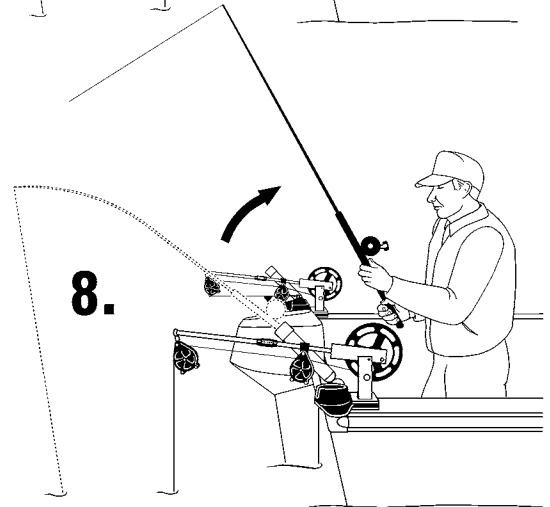
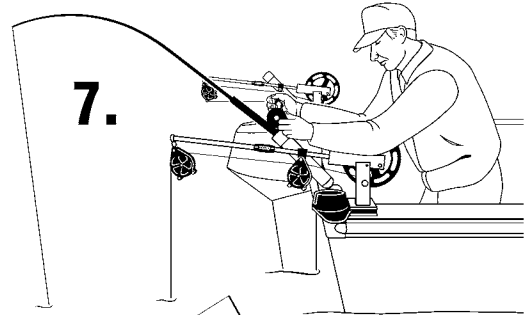
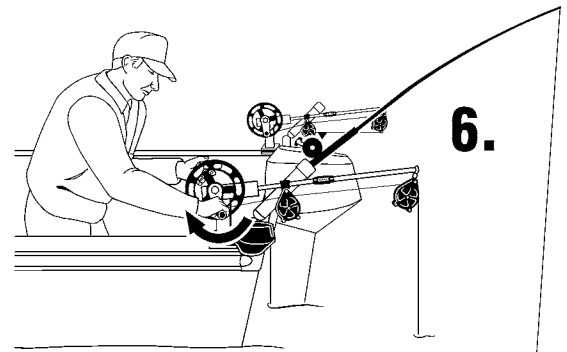

Operating Your Sportsman Electric Downrigger...

Take time to familiarize yourself with the controls of your Sportsman electric downrigger. On the left side of the downrigger (next to the reel), you will find the knob. Turn the clutch knob counter-clockwise to loosen it or clockwise to tighten it. Adjust the clutch so it will hold the weight of the cannonball. You may choose to set the clutch to act like the drag on your fishing reel and it will give cable if your cannonball becomes obstructed. Or you may tighten it down securely, which is recommended when fishing in rough water.

On the right side of the downrigger (next to the motor), you will find the switch cap that includes the Up/Down switch and the Circuit Breaker Reset Button. Press the bottom half of the switch to lower the cannonball. The Neutral/Stop position is with the switch returned to center. Press the top half of the switch to raise the cannonball. If you "Pop" the circuit breaker, return the Up/Down switch to the Neutral/Stop position (to prevent a runaway cannonball). Then wait 15 seconds and press the Circuit Breaker Reset Button.

Note: At the initial installation of your downriggers, hold the counter wheel firmly at zero and raise or lower the cannonball to the surface to set the depth counter. This will ensure that your depth counter is showing the depth of the cannonball.

1. While the boat is moving at trolling speed, set your fishing reel to free-spool, apply slight pressure to the spool with your thumb and let your lure to the desired distance behind the boat. Then set the drag clicker to stop your reel from free-spooling. Place your rod in the rod holder.
2. To place the line in the line release (the Band Buster® which comes with your downrigger is shown here), grab the fishing line and wrap a rubber band around the line and back through itself. With the other hand reach down and firmly take hold of the line release. Lift the cannonball out of the water and hook the rubber band to the line release. Then ease the cannonball back into the water. (**Read more about line releases on pages 21 and 22.**)
3. To lower the cannonball, press the bottom half of the Up/Down switch and let out the downrigger cable.

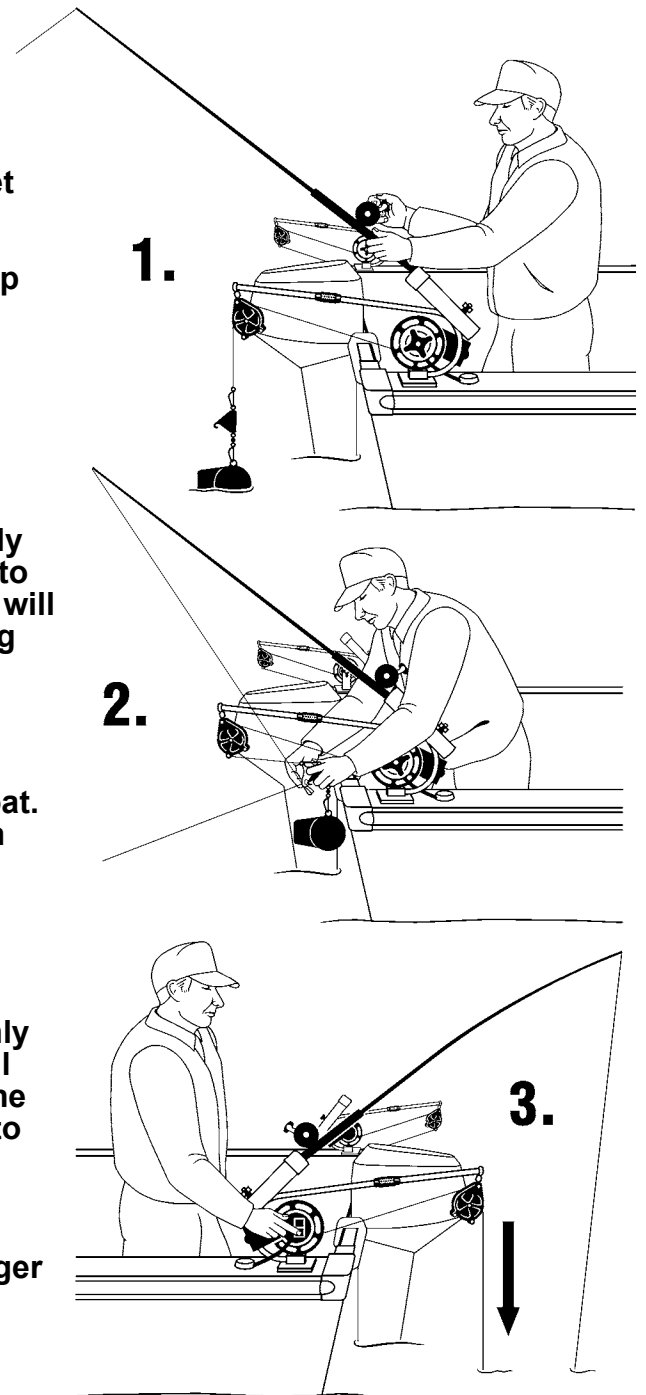
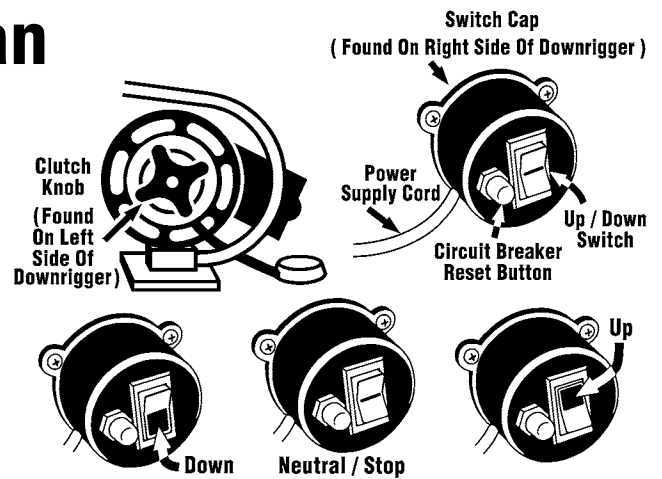

4. When the depth counter shows that the cannonball has reached the desired fishing depth, return the Up/Down switch to the Neutral/Stop position to keep the cannonball and your lure at that depth.

5. Next, set the drag clicker on your fishing reel. Then take up the slack in your fishing line, until there is a bow in your fishing rod.

(One of the virtues of using a Band Buster® line release is that when a fish strikes and pulls against the rubber band, the rod tip will start bouncing and signal the strike.)

6. When a fish strikes your lure or when you want to retrieve your lure, remove your fishing rod from the rod holder and abruptly lift your fishing rod to break the rubber band. Then fight and land your fish or retrieve lure.

Note: It is not necessary to bring in the other fishing lines and raise the cannonballs when a fish is "On". This is not necessary! Maintain your trolling speed and direction while you fight the fish from the back of the boat. Keeping the fish clear of your other lines is easier than you would think.

7. Finally, when you are ready to quit fishing or want to change lures, raise the cannonball by pressing top half of the Up/Down switch. Keep an eye on the depth counter and be prepared to turn off the downrigger as the cannonball reaches the surface. When the cannonball reaches the surface, return the Up/Down switch to the Up/Down position.

Option: For the boat owner who plans to run more than two electric downriggers, Big Jon Sports® offers the Auto-Stop System to automatically stop the downrigger motor when the cannonball reaches the pre-set shut-off depth (See "Setting The Auto-Stop's Shut-Off Depth" on page 9).

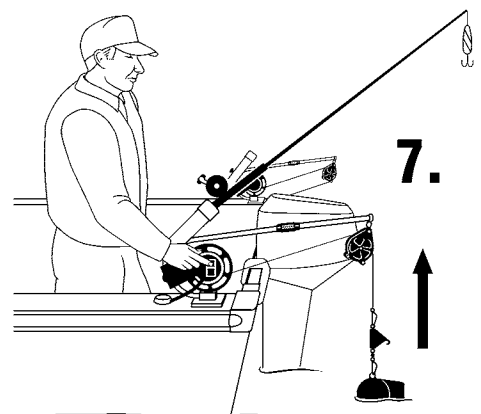
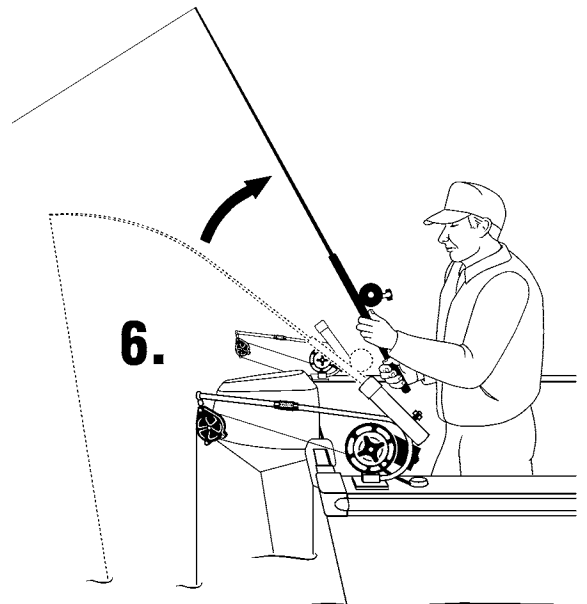
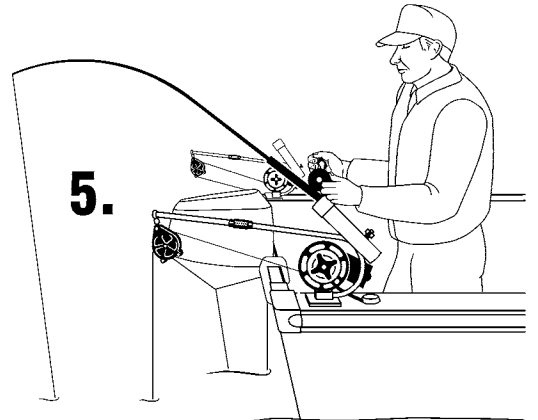
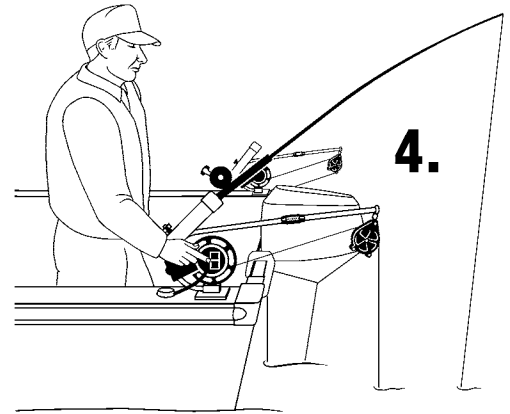

Operating Your Captain's Pak® Or Pro Tournament Electric Downrigger...

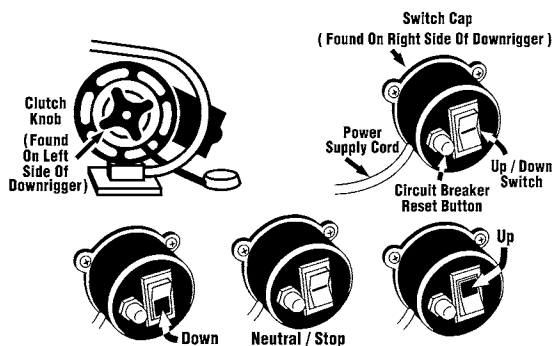

Take time to familiarize yourself with the controls of your Captain's Pak® or Pro Tournament electric downrigger.

On the left side of the downrigger (next to the reel), you will find the knob. Turn the clutch knob count clockwise to loosen it or clockwise to tighten it. Adjust the clutch so it will hold the weight of the cannonball. You may choose to set the clutch to act like the drag on your fishing reel and it will give cable if your cannonball becomes obstructed. Or you may tighten it down securely, which is recommended when fishing in rough water.

On the right side of the downrigger (next to the motor), you will find the switch cap that includes the Up/Down switch and the Circuit Breaker Reset Button. Press the bottom half of the switch to lower the cannonball. The Neutral/Stop position is with the switch returned to center. Press the top half of the switch to raise the cannonball.

If you "Pop" the circuit breaker, return the Up/Down switch to the Neutral/Stop position (to prevent a runaway cannonball). Then wait 15 seconds and press the Circuit Breaker Reset Button.

At the rear of the downrigger base plate, you will find The Boom Latch. This latch holds the boom in the upright position. Press the bottom of the latch to lower the Tip-Up Boom.

Note: At the initial installation of your downriggers, hold the counter wheel firmly at zero and raise or lower the cannonball to the surface to set the depth counter. This will ensure that your depth counter is showing the depth of the cannonball.

1. While the boat is moving at trolling speed, set your fishing reel to free-spool, apply slight pressure to the spool with your thumb and let your lure to the desired distance behind the boat. Then set the drag clicker to stop your reel from free-spooling. Place your rod in the rod holder.

1.

2.

3.

4.

5.

2. To place the line in the line release (the Band Buster® which comes with your downrigger is shown here), grab the fishing line and wrap a rubber band around the line and back through itself. With the other hand reach down and firmly take hold of the line release. Lift the cannonball out of the water and hook the rubber band to the line release. Then ease the cannonball back into the water.

(Read more about line releases on pages 21 and 22.)

3. Firmly hold the Tip-Up Boom and release the Boom Latch. Then lower the cannonball into the water.

4. Press the bottom half of the Up/Down switch to let out cable and lower the cannonball.

5. When the depth counter shows that the cannonball has reached the desired depth, return the Up/Down switch to the Neutral/Stop position to keep the cannonball and your lure at that depth.

6. Next, set the drag clicker on your fishing reel. Then take up the slack in your fishing line, until there is a bow in your fishing rod.

(One of the virtues of using a Band Buster® line release is that when a fish strikes and pulls against the rubber band, the rod tip will start bouncing and signal the strike.)

7. When a fish strikes your lure or when you want to retrieve your lure, remove your fishing rod from the rod holder and abruptly lift your fishing rod to break the rubber band. Then fight and land your fish or retrieve lure.

Note: It is not necessary to bring in the other fishing lines and raise the cannonballs when a fish is "On". This is not necessary! Maintain your trolling speed and direction while you fight the fish from the back of the boat. Keeping the fish clear of your other lines is easier than you would think.

8. Finally, when you are ready to quit fishing or want to change lures, raise the cannonball by pressing top half of the Up/Down switch. Keep an eye on the depth counter and be prepared to turn off the downrigger as the cannonball reaches the surface. When the cannonball reaches the surface, return the Up/Down switch to the Neutral/Stop position.

9. Lift the Tip-Up Boom and lock it in the upright Position. Then place the cannonball in the Ball Cradle.

Option: For the boat owner who plans to run more two electric downriggers, Big Jon Sports® offers the Auto-Stop System to automatically stop the downrigger motor when the cannonball reaches the pre-set shut-off depth (See "Setting The Auto-Stop's Shut-Off Depth on page 9).

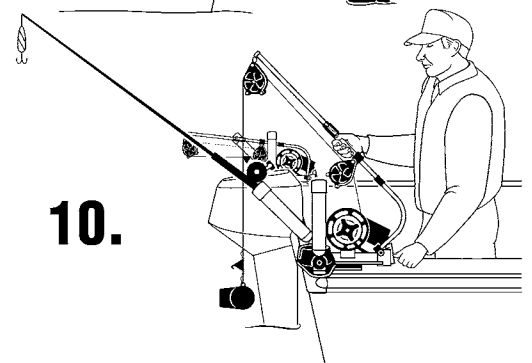
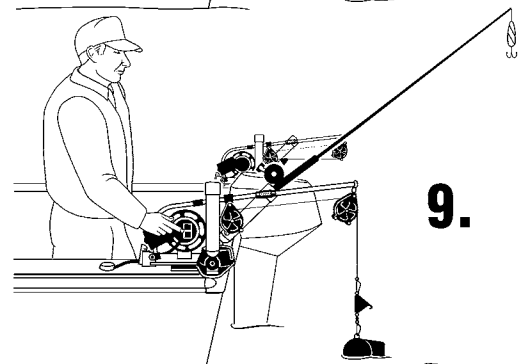
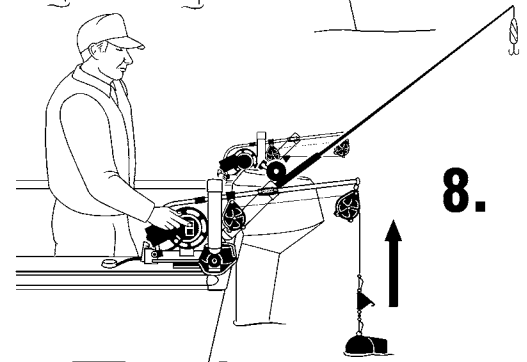
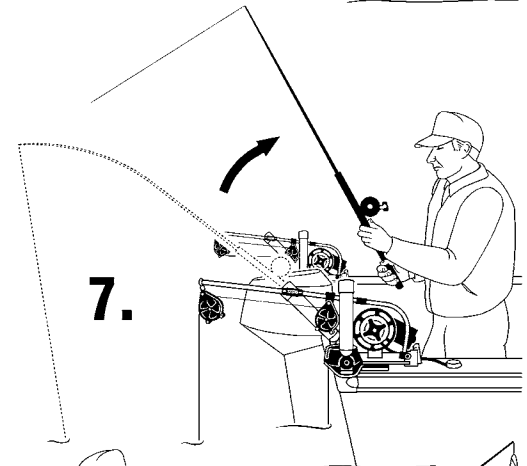
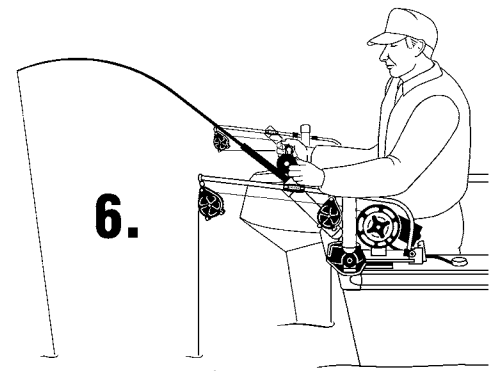

Operating Your Brute ES Electric Downrigger...

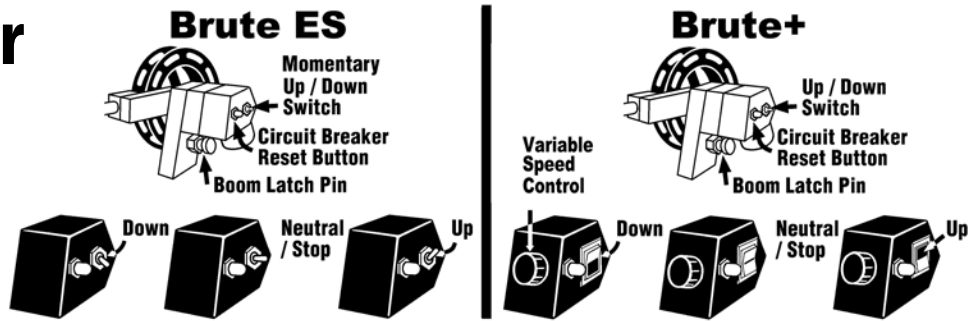

The Brute ES comes with a Momentary Up/Down Switch. The Brute + comes with a Constant Up/Down Switch, Variable Speed Control and Auto-Stop.

On the right side of the downrigger (next to the reel), you will find the clutch knob. Turn the clutch knob count clockwise to loosen it or clockwise to tighten it. Adjust the clutch so it will hold the weight of the cannonball. You may choose to set the clutch to act like the drag on your fishing reel and it will give cable if your cannonball becomes obstructed. Or you may tighten it down securely, which is recommended when fishing in rough water.

On the left side of the downrigger (next to the motor), you will find the switch cap that includes the Momentary Up/Down switch and the Circuit Breaker Reset Button. Press the switch Down to lower the cannonball. It will return to the Neutral/Stop position when you release it. Press it Up to raise the cannonball. Again, it will return to the Neutral/Stop position when you release it.

If you "Pop" the circuit breaker, release the Up/Down switch to let it return to the Neutral/Stop position (to prevent a runaway cannonball). Then wait 15 seconds and press the Circuit Breaker Reset Button.

On the left side of the Upright portion of the Brute ES downrigger base, you will find the Tip-Up Boom Latch Pin. This latch pin holds the boom in the upright position. Pull the latch out from the Upright to raise or lower the Tip-Up Boom.

Note: At the initial installation of your Brute ES downriggers, hold the counter wheel firmly at zero and raise or lower the cannonball to the surface to set the depth counter. This will ensure that your depth counter is showing the depth the cannonball.

1. While the boat is moving at trolling speed, set your fishing reel to free-spool, apply slight pressure to the spool with your thumb and let your lure to the desired distance behind the boat. Then set the drag clicker to stop your reel from free-spooling. Place your rod in the rod holder.

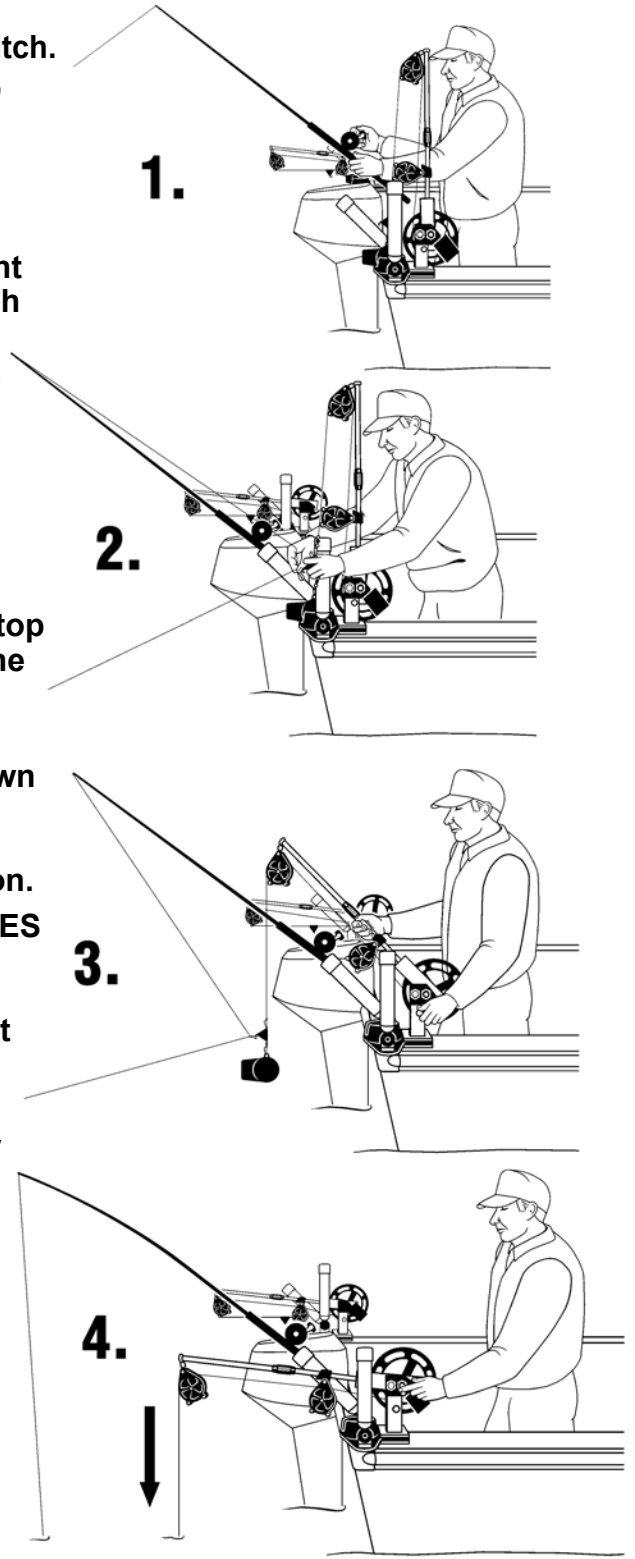

2. To place the line in the line release (the Band Buster[®] which comes with your downrigger is shown here), grab the fishing line and wrap a rubber band around the line and back through itself. With the other hand reach down and firmly take hold of the line release. Lift the cannonball out of the water and hook the rubber band to the line release. Then ease the cannonball back into the water.
(Read more about line releases on pages 21 and 22.)

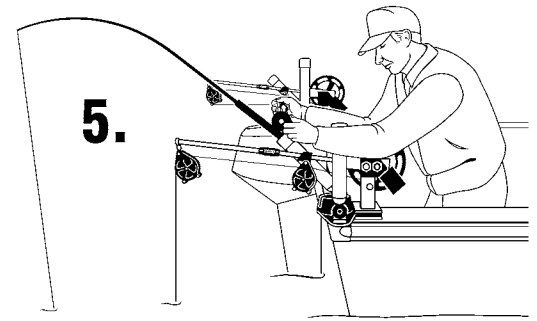

3. Firmly hold the Tip-Up Boom and release the Boom Latch. Then lower the cannonball into the water.

4. Press the switch Down let out cable and lower the cannonball. When the depth counter shows that the cannonball has reached the desired depth, release the Up/Down switch and let it return to the Neutral/Stop position to keep the cannonball and your lure at that depth.

5. Next, set the drag clicker on your fishing reel. Then take up the slack in your fishing line, until there is a bow in your fishing rod.
(One of the virtues of using a Band Buster[®] line release is that when a fish strikes and pulls against the rubber band, the rod tip will start bouncing and signal the strike.)

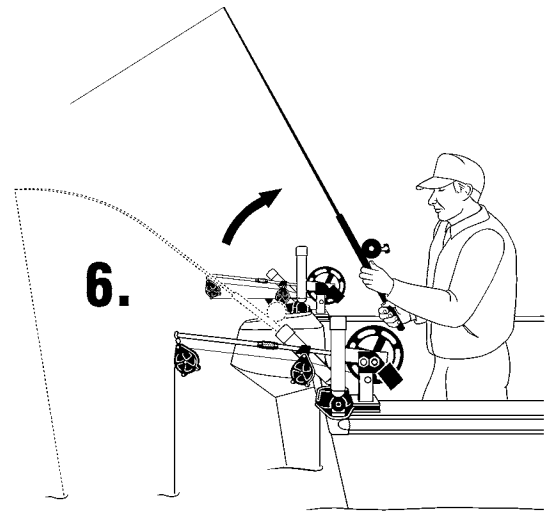

6. When a fish strikes your lure or when you want to retrieve your lure, remove your fishing rod from the rod holder and abruptly lift your fishing rod to break the rubber band. Then fight and land your fish or retrieve lure.

Note: It is not necessary to bring in the other fishing lines and raise the cannonballs when a fish is "On". This is not necessary! Maintain your trolling speed and direction while you fight the fish from the back of the boat. Keeping the fish clear of your other lines is easier than you would think.

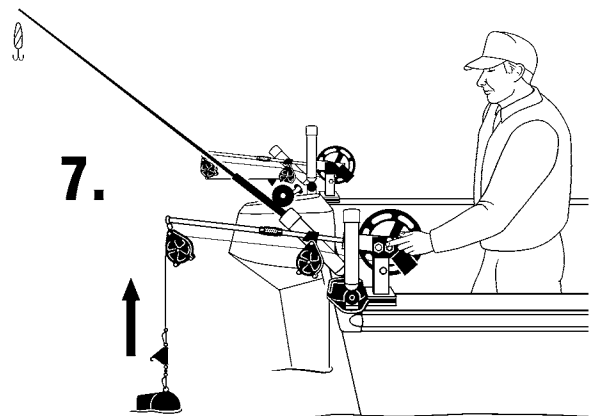

7. When you are ready to quit fishing or want to change lures, "Pop-Off" your line release, retrieve your lure and place your rod in the rod holder.

8. Then press the Momentary Switch Up to retrieve the cannonball. When the cannonball surfaces, release the Momentary Switch and let it return to the Neutral/Stop position.

9. Lift the Tip-Up Boom and lock it in the upright position. Then place the cannonball in the Ball Cradle.

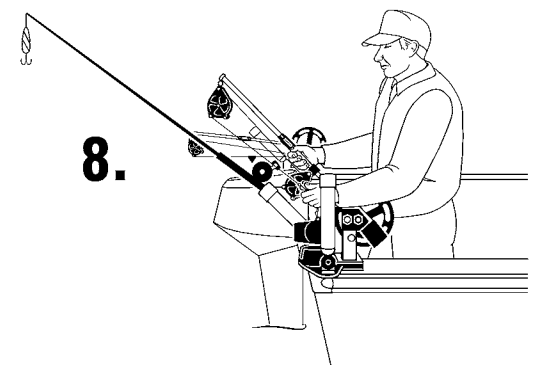

Using Big Jon Sports® Line Releases...

The Band Buster® Release

“The Line Release That Signals When A Fish Strikes”...

1. After letting your line out to the distance that you want it to run behind the boat, loop a rubber band (# 31 or lighter) around your fishing line and back through itself. Then pull the rubber band tight around the fishing line
2. Place the rubber band in the hook on the back of the Band Buster® line release. The tension from the lure will keep the rubber band secure on the hook.
3. When a fish strikes your lure, the weight of the fish pulling on the fishing line will stretch the rubber band and cause the tip of your fishing rod to “bounce” and give you an unmistakable signal that you have a fish on that line.
4. When you see that you have a fish on one of your lines, grab that rod and lift it abruptly to break the rubber band. You are free to fight and land your fish.

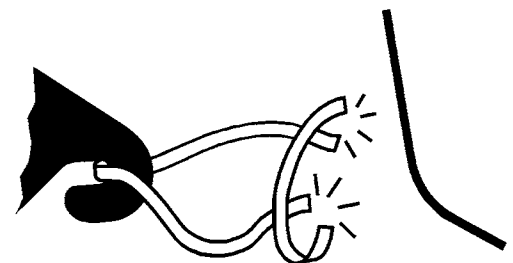
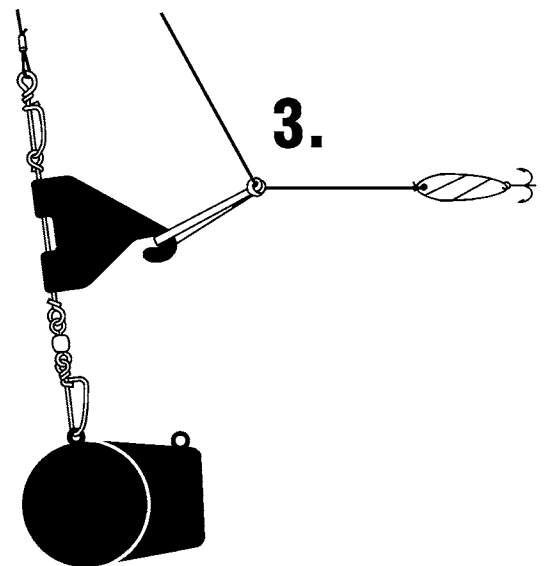
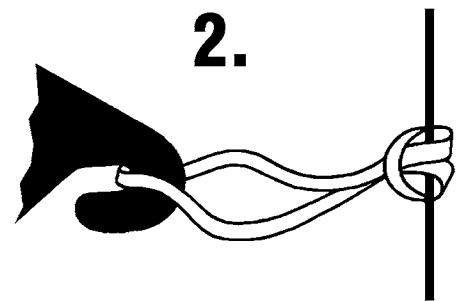
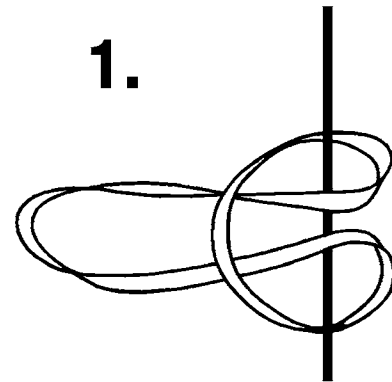

4.

The Free'n® Easy Release

"The Line Release That Is The Favorite Of Successful Charter Captains And Tournament Fishermen!"...

The Free'n Easy® downrigger line release is an "adjustable tension" line release that will withstand greater tension from the fishing rod than other line releases and still trip easily from the lightest fish strike.

1. Adjust the tension screw turning it clockwise to strengthen the release tension, or turn it counter clockwise to lighten the release tension.
2. Once you have the tension set to your liking, lock the tension screw in place by turning the locking nut clockwise until it is set tightly against the body of the line release.
3. To attach your fishing line to the line release, start from the front of the release pin (the end nearest to the downrigger cable) and wrap the line around the release pin four times in a counter clockwise direction.
4. Press the release pin into the body of the release until it rests against the spring-loaded catch.
5. Lower the cannonball and lure to the desired fishing depth.
6. With your fishing rod in the rod holder, reel in the slack in your fishing line until your fishing rod bows under the tension.
7. When a fish strikes, it will pull the pin from the body of the release. The fishing line will then roll off the end of the release pin. When this happens you will see the fishing rod pop up from the bowed position.

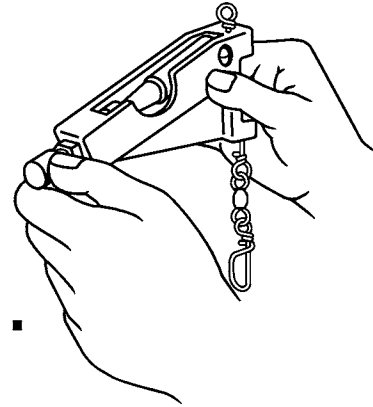

1.

2.

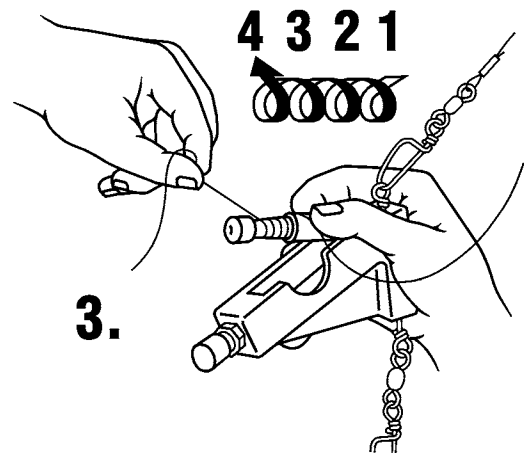
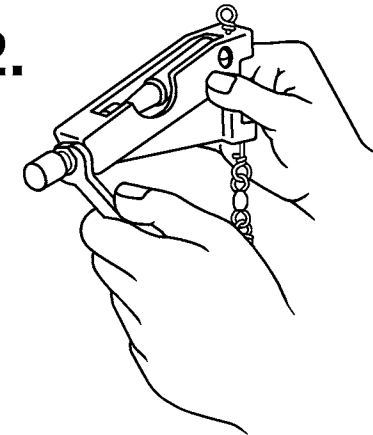

3.

4.

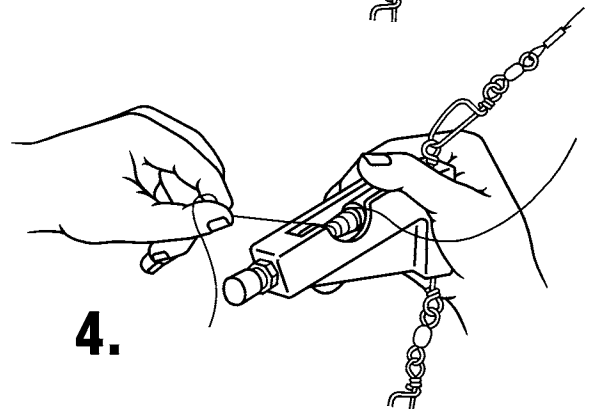

Operating Your Big Jon Sports® Planer Rigger System...

1. Start by preparing two tow line retrieval lanyards made of a couple of shower curtain hangers and a couple of lengths of tow line cord. Then, with your fishing rods prepared with the lures of your choice and placed in your boat's rod holders, bring your boat to trolling speed and maintain that speed.
2. Place your Otter Boat® (planer) in the water. Take hold of the reel with one hand and loosen the clutch by turning the clutch knob counter-clockwise with the other hand.

NOTE: The Big Jon Sports® Otter Boat® is recommended as a good choice of planers because of its ability to gain greater distance from your boat than the old fashion boards and skies.
The Otter Boat® also performs better in rough water and doesn't stall when your boat is making a turn.

3. Let out the tow line by turning the planer rigger reel clockwise. Do this slowly so that the tow line stays tight and the Otter Boat® can plane out from the side of your boat. When the Otter Boat® has reached the distance from your boat that you desire, retighten the clutch knob securely. Repeat steps 2 and 3 on the other side of the boat.
4. Now, take your first fishing rod from the front rod holder and place your lure in the water. Let your lure out to the distance that you want it to run behind the boat. Reset your reel so it doesn't free-spool and place your rod back in the rod holder.

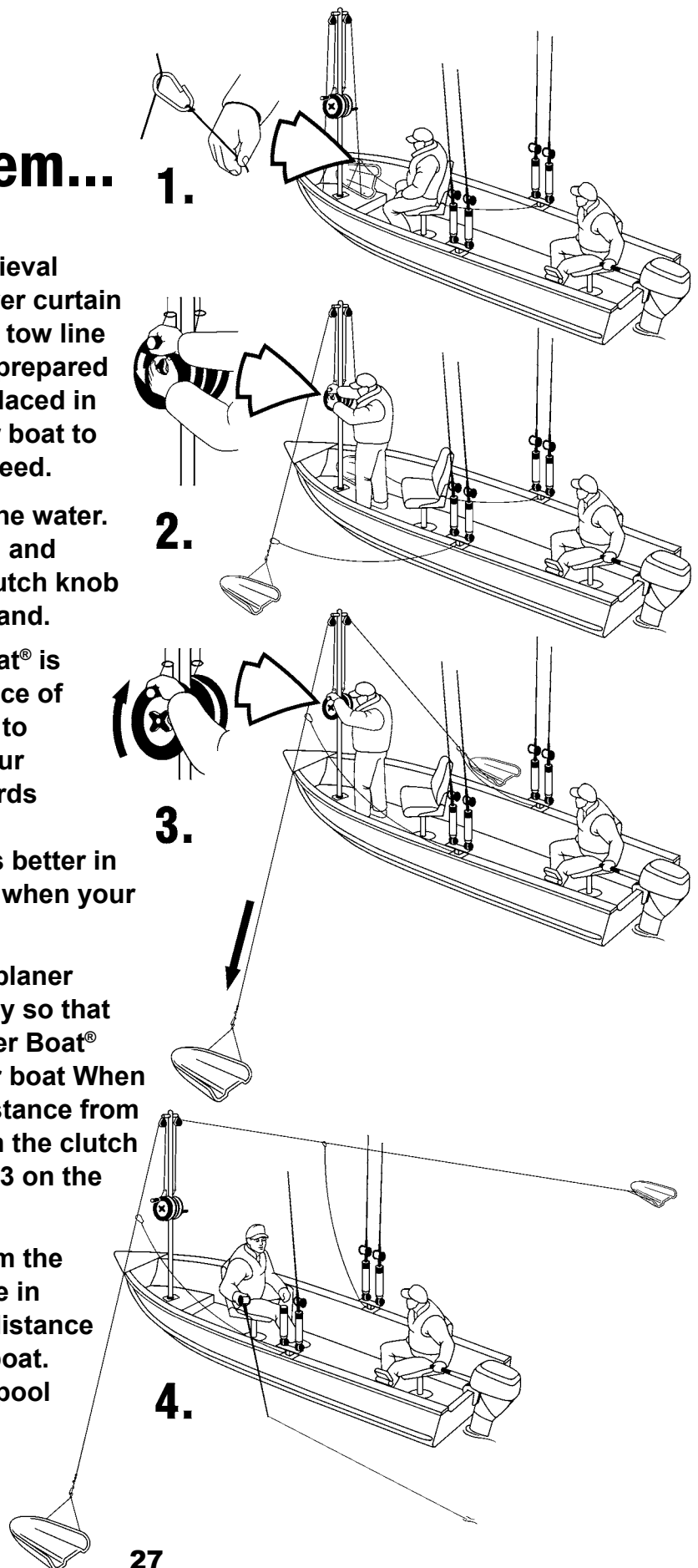

5. Take hold of the fishing line that you have just let out and attach a line release to it (A). (There are many styles of line releases on the market to choose from. We are showing the “Pinch Pad” style here). Then, use the retrieval lanyard to pull the planer board tow line within reach. Clip the line release hanger clip around the tow line and close the hanger clip (B). Then, let out the retrieval lanyard until the tow line has returned to it’s normal position.

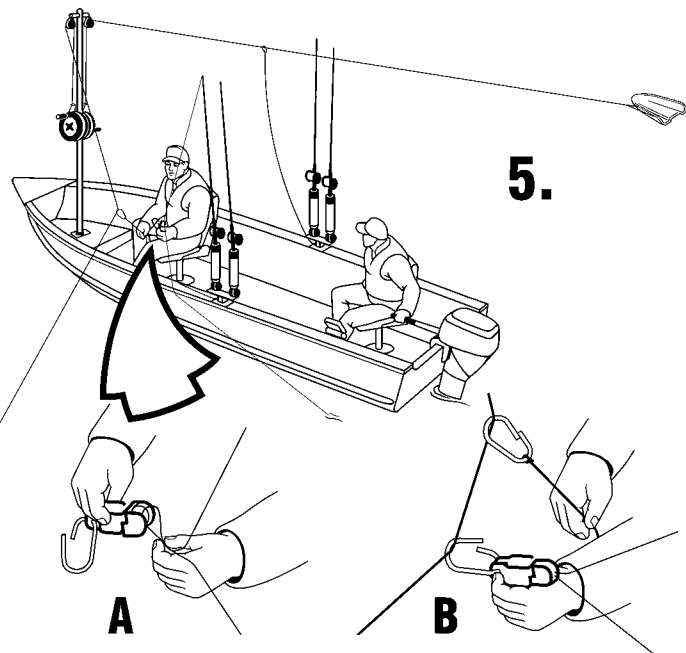

6. Remove your fishing rod from the rod holder and let out more fishing line. As you do this, the line release will slide down the tow line. Stop the first line just short of the Otter Boat®. (This line should be run with a shallow running lure). Now, set the drag and drag clicker on your fishing reel and place your fishing rod back in the rod holder closest to the front of the boat.

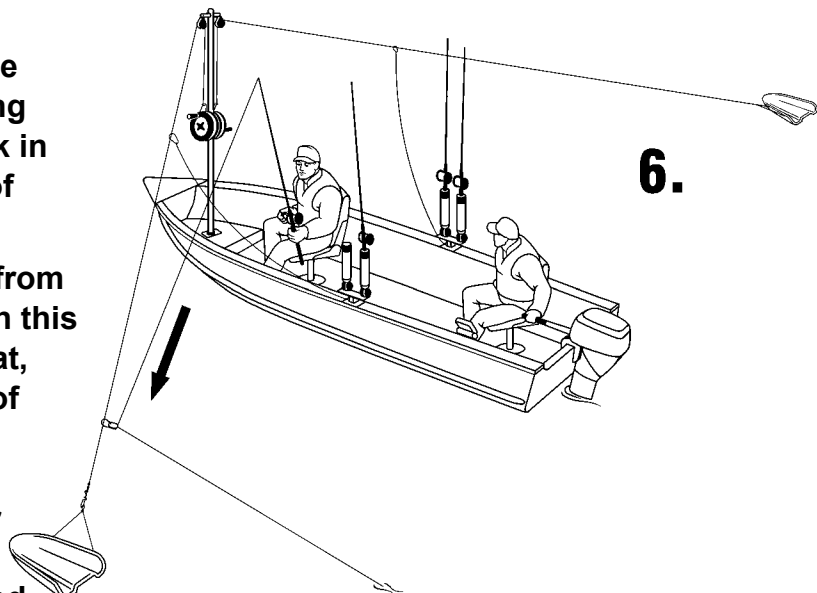

7. Now, take your second fishing rod from the rod holder and repeat step 4. On this fishing line, that is closer to the boat, you may choose to vary the depth of your lure presentation by using a Mini-Diver or Deep'R Diver® disk attached about 4 feet ahead of your lure. Now repeat steps 5 and 6 and place your fishing rod in the next rod holder back from the back from the first rod holder.

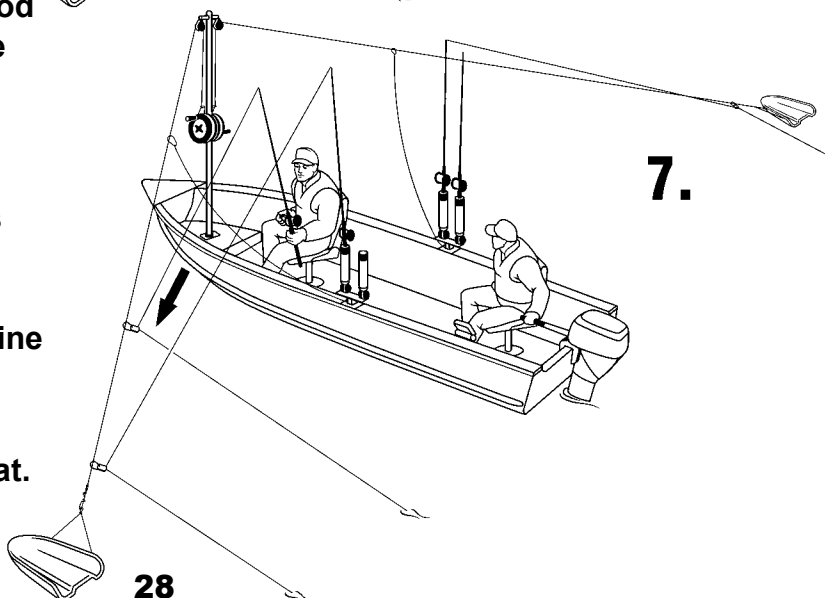

NOTE: Each successive fishing line added to the tow line should be placed below the previous fishing line to avoid tangling with other lines when a fish strikes and pulls the fishing line from the line release.

Now, you are ready to repeat steps 4 through 7 on the other side of the boat.

Using The Big Jon Sports® In-Line Planers...

1. Bring your boat to trolling speed. Then let your lure out to the desired fishing distance behind the boat. Once your lure is out to the desired distance, set the drag clicker on your reel to prevent it from free-spooling. Then place your fishing rod in the rod holder.
2. Take hold of the fishing line and clip the swivel clip (at the back of the planer) around the line (as shown in drawing A). Then, attach the line release to the fishing line, ahead of the swivel clip (as shown in drawing B).
3. Remove your fishing rod from the rod holder and place the planer in the water. Keep your rod tip high and let out line until the planer moves out to the desired distance from the boat.

NOTE: The maximum distance that an in-line planer will move away from a boat is governed by the height of the fishing rod's tip. This makes longer fishing rods desirable when fishing with in-line planers.

4. When the in-line planer has reached the desired distance from the boat, set the drag clicker on your reel to prevent it from free-spooling. Then, place the fishing rod in the front rod holder. Set the rod holder to hold the fishing rod straight up to keep the rod tip as high as possible. This will allow the planer to gain the greatest distance from the boat. Next, repeat steps 1 through 4 with the fishing rod in the rear rod holding. Then follow the same procedure for the rods on the opposite side of the boat.

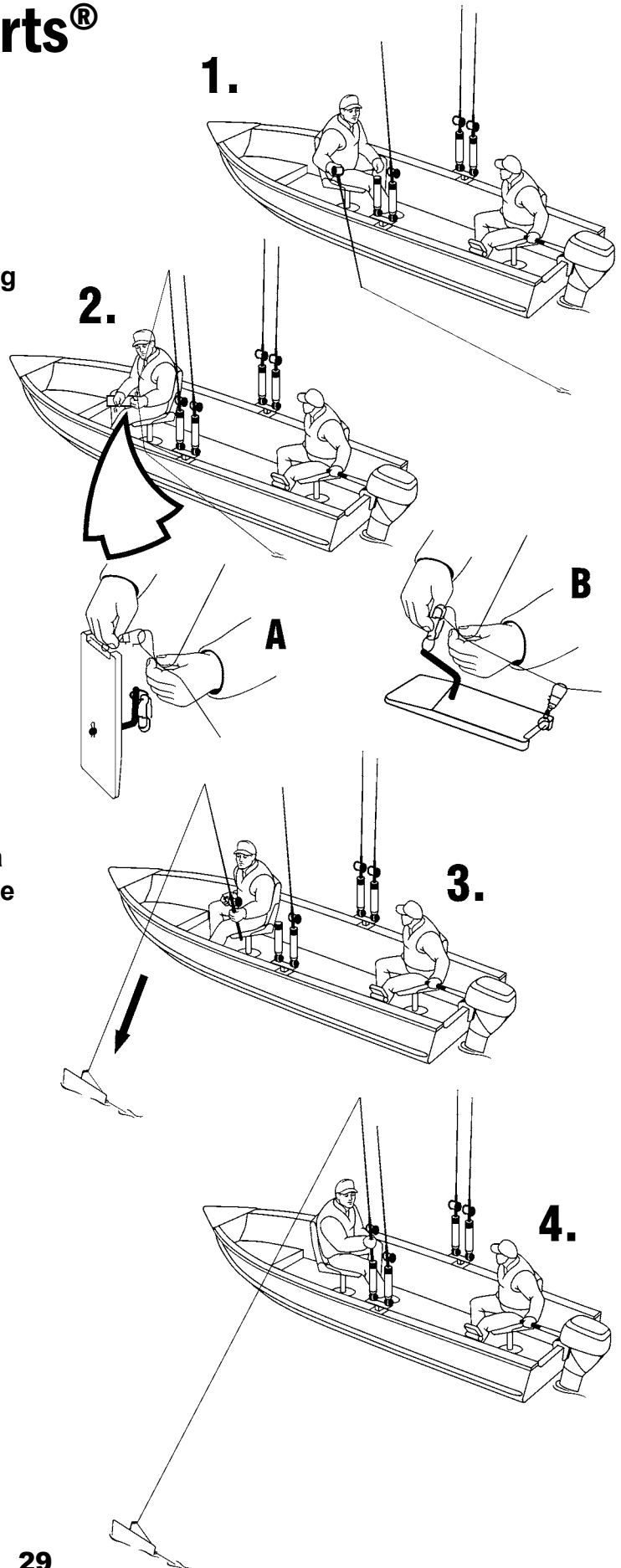

5. When a fish strikes your lure, the line release will “Pop-Off”, allowing the planer to slide down the line to a “Speedo Bead”. The Speedo Bead is placed approximately 18 inches in front of the lure to keep the planer from interfering with the fish.

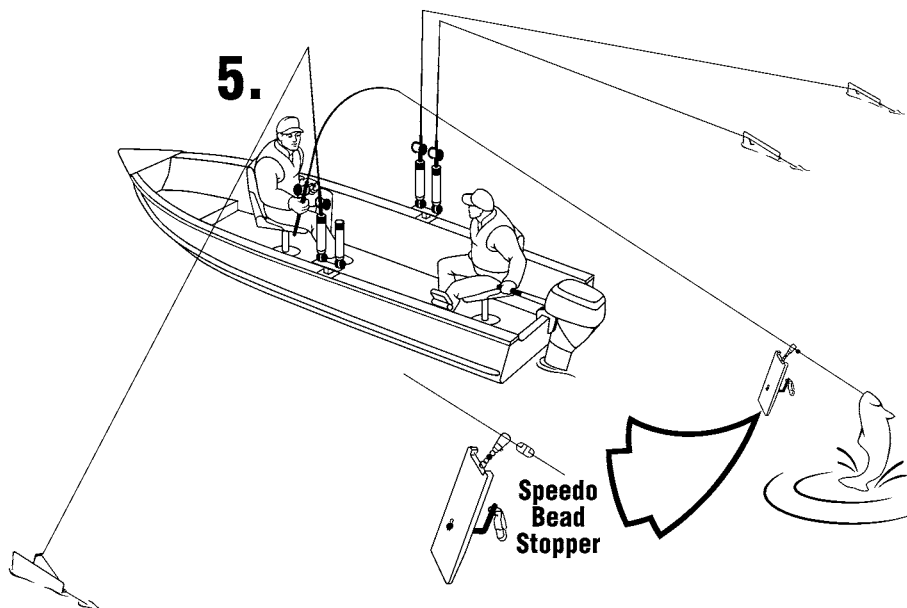

In-Line Planer Line Releases...

Otter® Release

The Otter® Release is the “Plug and Barrel” style of release. To use it, fit your fishing line into the notch in the plug end of the release. Then press the plug and fishing line into the barrel end of the release.

The amount of pressure you apply when inserting the plug will determine if it will “pop-off” with a light or hard strike.

Otter®
Release

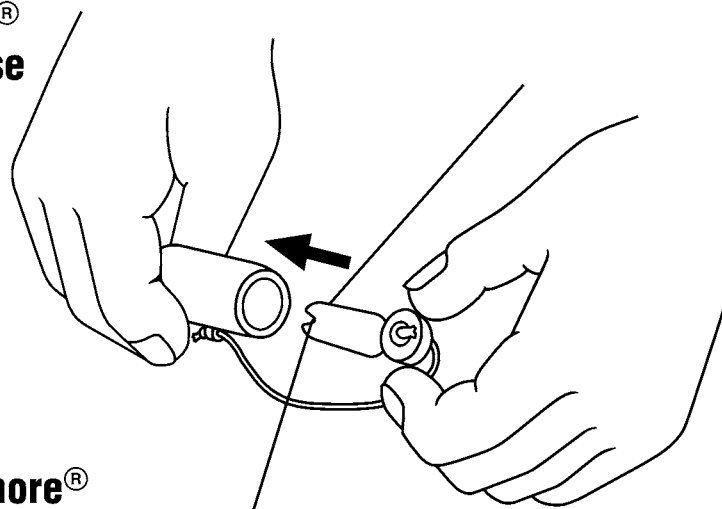

Offshore®
Release

Offshore® Release

The Offshore Release is a “Pinch Pad” style of release. To use it, pinch top and bottom halves of the release to open the pads. Then insert the fishing line between the pads and release the pressure to allow the pads to close around the fishing line.

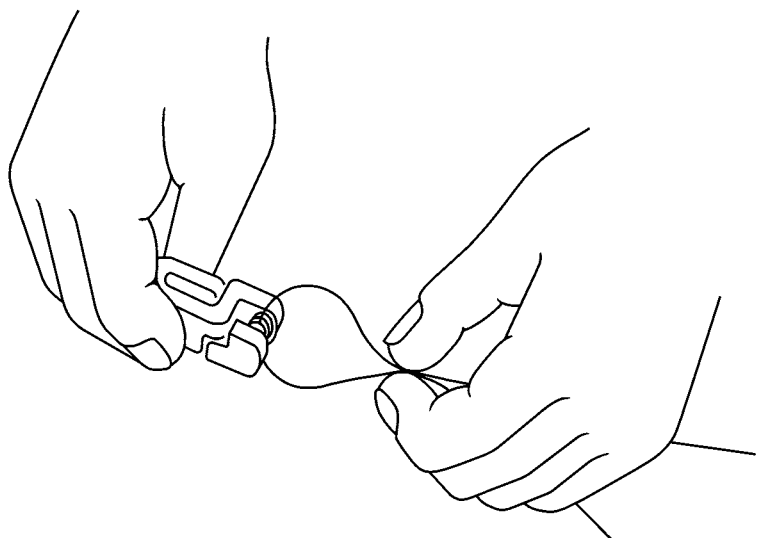

Using The Big Jon Sports® Mini-Diver And Deep'r Diver® Disks...

You will find that the Big Jon Sports® Mini-Diver and Deep'r Diver® disks are the easiest diver disks you can use.

1. Start by tying the line coming from your fishing rod to the clip located on the top and center of the diver disk. Then, tie a length of line (approximately four feet long) to the rear clip on the disk. Tie your lure to the other end of this line.

If you use a shorter rod, the lure should be approximately twelve inches from the reel, when the diver is at the rod tip.

2. The nose weight on the bottom of the diver disk determines the direction the diver will travel from the boat. When the nose weight is set at the center mark, the diver will travel straight back from the boat. Move the nose weight to the right (when viewed from the bottom of the diver) and the diver will travel to the right side of the boat. Move the nose weight to the left (when viewed from the bottom of the diver) and the diver disk will travel to the left side of the boat.

3. While the boat is at trolling speed, place your lure and then the diver in the water and let out your line. Apply slight pressure to the reel's spool with your thumb to create some resistance for the diver to work against. The diver disk will work against the water's resistance and pull down to a

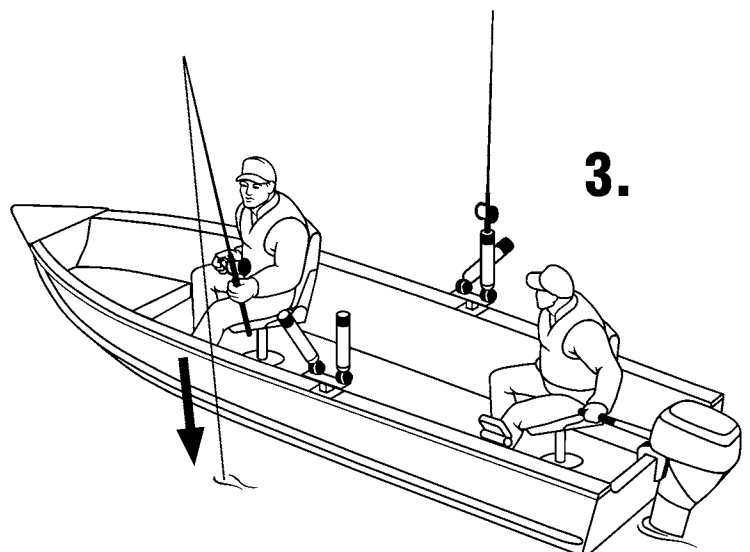
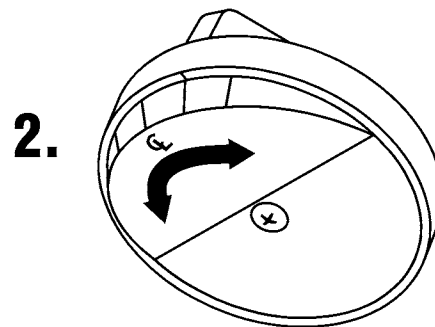
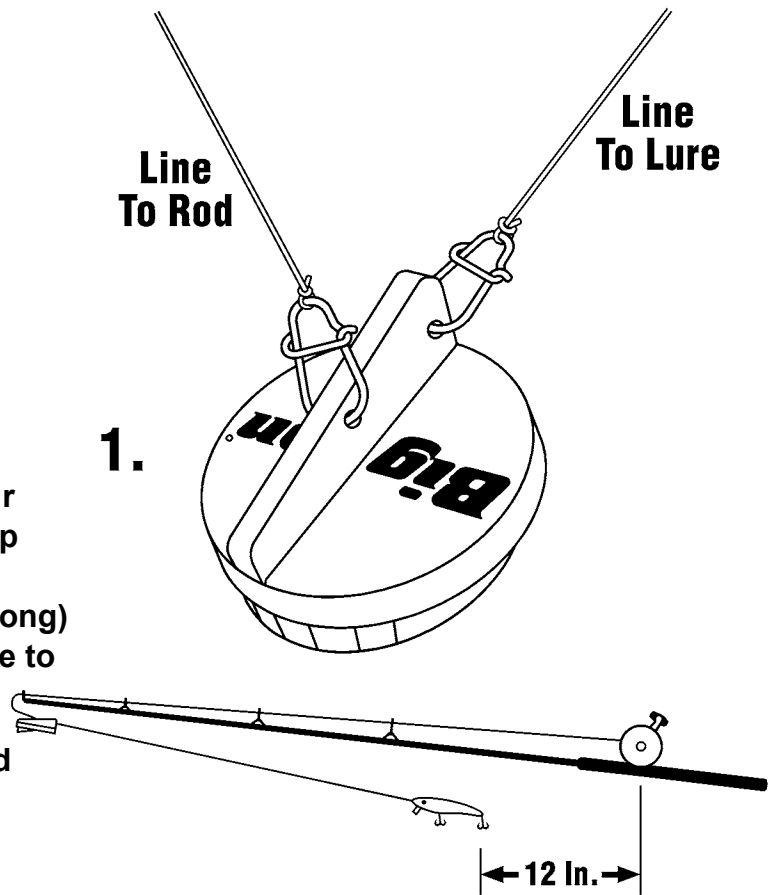

4. As you are letting out your fishing line, you will reach a point where your line starts to move back towards the rear of the boat. When this happens, the diver has reached it's maximum depth.

Because of many variables, such as speed, line weight, lure weight and water temperature that affect the performance of any diver, there are no exact charts to determine how much line to let out to reach a given depth.

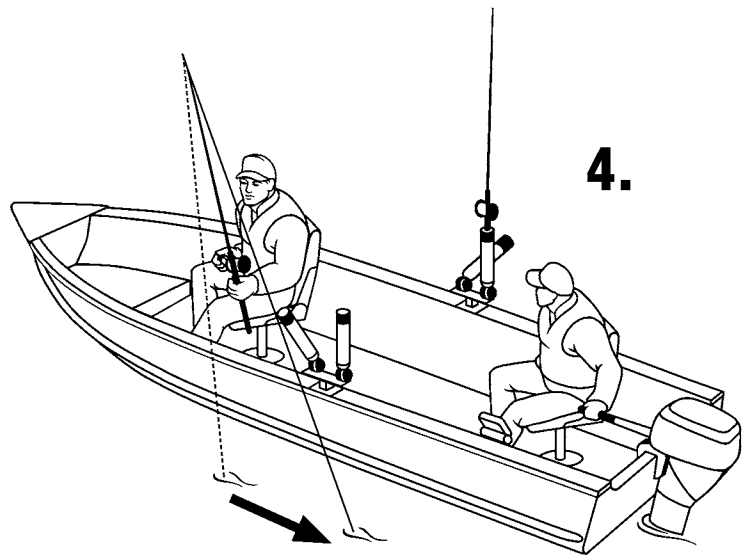

5. Once the diver has reached it's maximum depth or the depth you've decided to stop at, set the drag clicker on your reel to prevent the reel from free-spooling and place your rod in a rod holder.

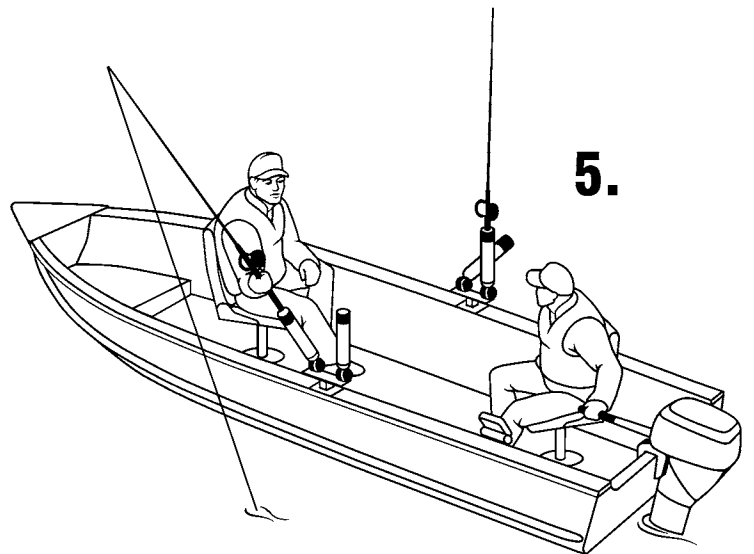

Now you are ready to repeat steps 1 through 5 with your remaining fishing rods.

6. When a fish strikes your lure, the tension of the fish pulling on the fishing line will cause the diver disk to be pulled straight in-line with the fishing line. This feature eliminates any water resistance, so you fight only the fish. No "Pop-Off" release is needed when you are using Big Jon® diver disks.

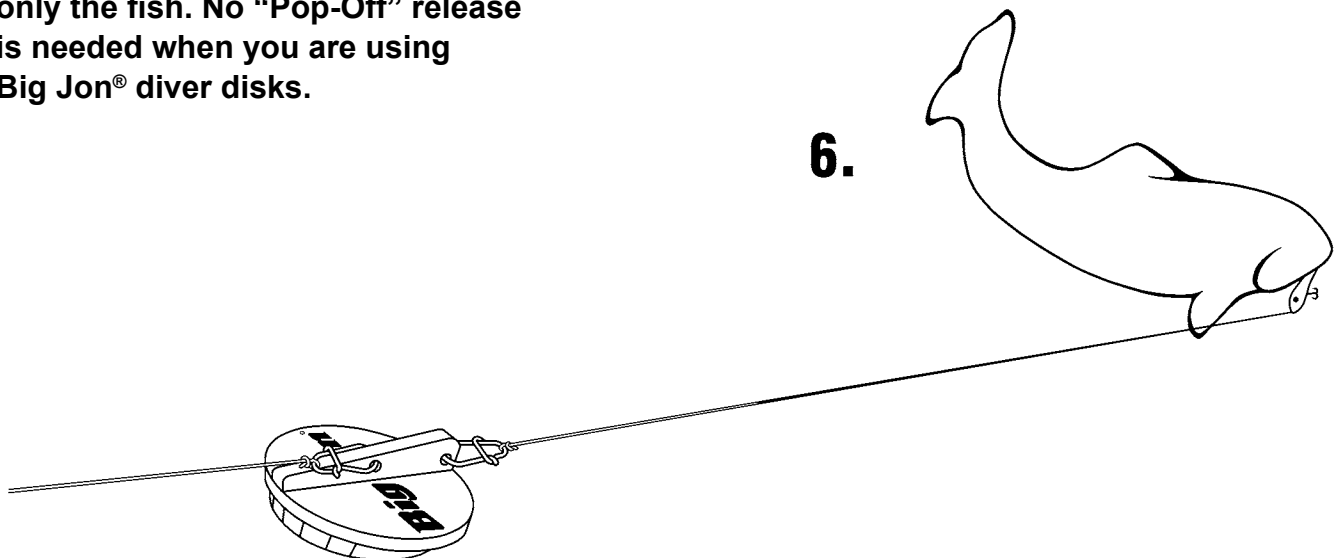

Thermoclines On Inland Lakes

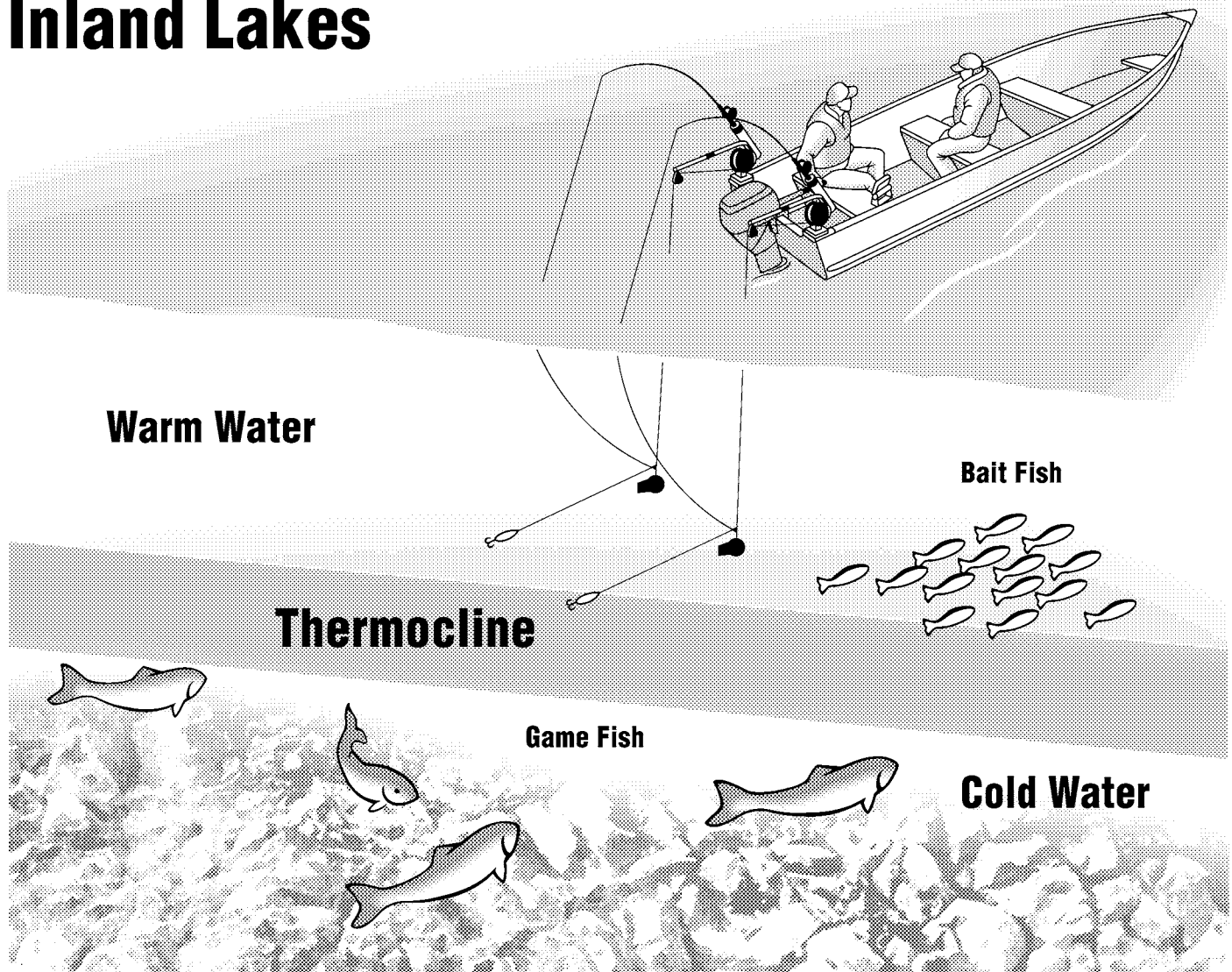

Locating feeding fish is one of the most important skills a fisherman can develop. You can mark fish on your fish finder and not entice them to strike your lure if they are not in their “Feeding Zone”!

Most species of fish have a preferred temperature of water that they will actively feed in. Find this area of temperature with fish present and you will greatly increase your chances of catching fish.

Remember, fish are cold blooded. In water that is too cold, fish will be dormant, sluggish and will not feed. In water that is too warm, they will be seeking a more comfortable environment. So an understanding of understanding

of how different temperatures of water break up will help you locate feeding fish.

Here are the two main ways different temperatures of water will break up.

On inland lakes, water temperatures tend to settle into horizontal layers of warm and cold water that are separated by a moderating layer, known as the “Thermocline” (a zone of rapid temperature change). While the cold water below the thermocline may be depleted of oxygen, the thermocline usually contains sufficient oxygen for cold water species like Salmon and Trout. This will be the depth where you will find the best fishing.

Temperature Breaks On The Oceans And Great Lakes

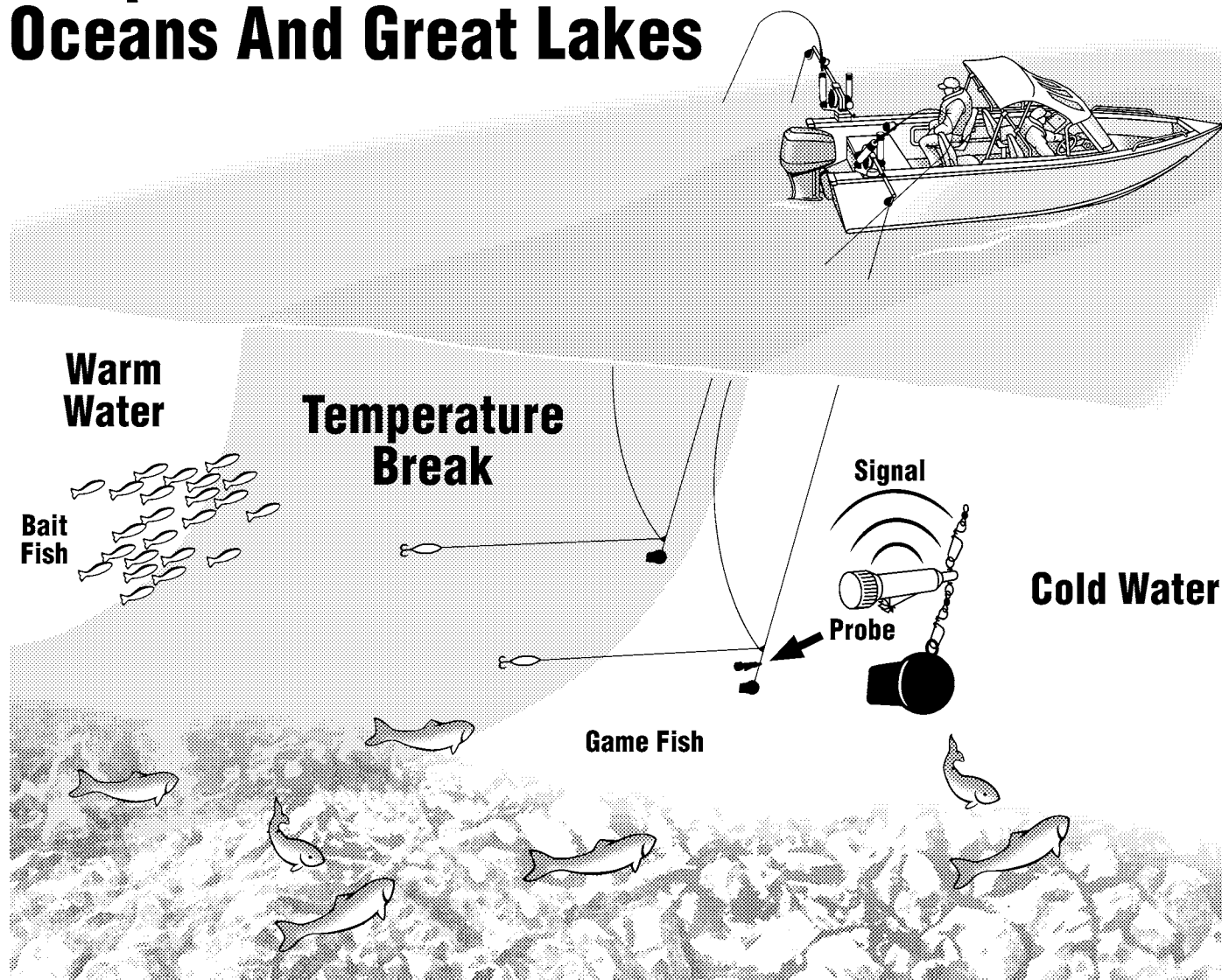

On larger bodies of water, like the oceans and the Great Lakes, masses of water temperature are much larger and in a constant state of change. The location of these large masses of temperature are highly affected by changes in weather conditions. These large masses of warm and cold water also have a moderating layer known as a "Temperature Break" (also referred to as "scum lines"). Scum lines are teeming with microorganisms, aquatic insects, bait fish and, of course, game fish.

Because of the constant shifting of the warm and cold masses of water, a temperature break often appears as a vertical layer. The temperature break will be the most active feeding zone and offer the best fishing.

Taking out the guess work...

Equipped with modern electronics, today's fishermen need not go fishing "blind"! With fish/depth finders they know what is going on below. And with a "submersible probe" like the Fish Hawk® Thermo-Troll # 840, speed and temperature can be read at the cannonball as well as the surface. (Often there are vary different readings between the two depths).

Another "high-tech" asset used on the Great Lakes is to study "Surface Temperature" maps, gathered via satellite. (The maps are updated daily).

To access the maps go to:

www.bigjons.com

(This Warranty Supersedes The Warranty On The Back Cover Of The Owner's Manual, Effective On Purchases Made On 1/1/15 Or Later)

Warranty And Service

For All Components Manufactured By Big Jon Sports®

(THIS PRODUCT MUST BE REGISTERED FOR THE WARRANTY TO BE VALID!)
(COMMERCIAL APPLICATIONS ARE NOT COVERED BY THIS WARRANTY!)

Big Jon Sports® Inc. hereby warrants (**Parts manufactured by Big Jon Sports®**) the product listed below, to the original purchaser (nontransferable), when the product is registered by mail or electronically through our website (**within 30 days of purchase**). Big Jon Sports® products are warranted against defective workmanship and/or material defects when used for the purpose intended, under normal conditions, and provided the product receives proper care. The following schedule indicates the specific duration of time & description of warranted products.

Fill out the Registration Form at the bottom of this page and mail it to:

Big Jon Sports® • 11455 US-31 South • Interlochen, MI 49643

OR go on-line at www.bigjonsports.com and click on "Lifetime Warranty" at the top of the home page and fill out the Electronic Registration Form at the bottom of the Lifetime Warranty page.

Big Jon Sports® products covered by a Lifetime Warranty are as follows:

All parts manufactured by Big Jon Sports® (Example: Main Components machined from aluminum or stainless steel).

Big Jon Sports® products covered by a 6 Month Year Warranty are as follows:

All Plastic Parts, Motors, All Rod Holders, Net Holders, Transom Bars, Mounting Bases, Ball Cradles, Mini-Divers, Deep'r Divers®, Otter® In-Line Planers, Mini-Otter® In-Line Planers, Side-Liner® In-Line

Planers, Otter® Boats, All Line Releases, Motor Covers, Cable Caps, Lock-Down Bolts, Snubbers and Replacement Parts.

Big Jon Sports® products not covered by a Warranty are as follows:

- All Wear Parts - Example: Clutch Systems, Cable.
- Rubber Bands and Apparel.

Making Warranty Service Arrangements:

You may contact the Big Jon Sports® Service Department by calling: (231) 275-1010 between 8:00 am and 4:00 pm (Eastern Time), Monday through Friday.

The warranty provided herein is in lieu of all other expressed warranties. All other obligations or liabilities, including liabilities for consequential damages, or losses are hereby excluded.

Big Jon Sports® Service Department

Big Jon Sports® Inc. builds the best trolling products available. We are committed to providing our customers with the best service in the sport fishing industry! You will be greeted in a polite, friendly manner by our knowledgeable service technicians.

Just call: (231) 275-1010 or go on-line at:

www.bigjon.com

Then click SERVICE in the main menu bar to email your questions directly to our Service Department.
We will respond to your emails promptly, in most cases within 24 hours.



Big Jon Sports® • 11455 US-31 South • Interlochen, MI 49643
Phone: (231) 275-1010 • Fax: (231) 275-1009